

INSTALLATION AND OPERATING INSTRUCTIONS



CONTENTS

Installation	2
a) Control Panel	2
b) Sensors	3
c) View of Panel	5
d) System Wiring	6
Display	11
User Interface	12
Select System Type	12
A. Space heating only with outdoor reset	13
a) Dip switch settings	13
b) Functions and defaults	15
c) Adjusting the settings	15
B. Space heating only w/setpoint control	18
a) Dip switch settings	18
b) Functions and defaults	18
c) Adjusting the settings	18
C. Space heating w/DHW w/outdoor reset	19
a) Dip Switch Settings	19
D. Space heating w/DHW w/setpoint control	20
a) Dip switch settings	20
b) Functions and defaults	21
c) Adjusting the settings	21
Detailed Information for Adv Mode of	
Adv / Installer Dip Switch	22
Viewing the Performance	27
Useful Hints and Reloading Factory Defaults	28
Testing the control	29
Error Messages	30
Technical Data	31
Factory Default Listings	32

SC-9 Applications

- Space heat systems with outdoor reset
- Constant temperature setpoint control
- Any of these in combination with domestic hot water heating

If your system is different than the above, call the Slant/Fin technical services group at 800-873-4346 to determine if the control can accommodate it.

The SC-9 is a microprocessor control which will sequence up to nine heating stages based on outdoor air temperature and supply water temperature. Designed to handle a Caravan gas-fired, oil-fired or dual fuel-fired hot water heating plant for space heating or "Setpoint" operation, or either in combination with domestic water heating. A large easy to read display provides current system temperatures and operating status. The control has outputs for a primary pump and either a combustion air damper or alarm.

ADDITIONAL FUNCTIONS INCLUDE:

Primary pump output. Pump exercising. Pump purging. Boiler demand for space heating loads. Set point demands for set point loads. Test sequence to ensure proper component operation. CSA C US certified. Setback input for energy savings.

SPACE HEATING OPERATION: When the outdoor air temperature drops below a preset value, the heating system is energized. The SC-9 Controller determines the number of stages required to meet the space heating needs and fires them. During operation, the Controller scans system temperatures, adding or deleting stages as necessary to satisfy heating load.

Controller Packing List

1- SC-9 Modular controller	P/N 435081
1- Outdoor sensor with enclosure	P/N 339070
2- Universal sensors	P/N 339071
1- Used as supply water sensor	
1- Used as return water sensor	

SETPOINT OPERATION:

The SC-9 adds and deletes stages to minimize the difference between the desired Setpoint temperature and the actual measured Supply Water Temperature.

DOMESTIC WATER HEATING:

When configured for "DHW" (Service Water Heating), the control holds stage #9 out of the Lead/Lag firing sequencing until all other active stages are energized. Only when the heating load reaches a maximum will the Stage #9 relay energize. At the same time, a motorized valve opens allowing the DHW modules to contribute to space heating. If water temperature in the DHW modules falls below a pre-set value, the motorized valve will close, retaining module capacity for domestic water heating.

INSTALLATION

CAUTION

Improper installation and operation of this control could result in damage to the equipment and possibly even personal injury. It is your responsibility to ensure that this control is safely installed according to all applicable codes and standards. This electronic control is not intended for uses as a primary limit control. Other controls that are intended and certified as safety limit must be placed into the control circuit. Do not open the control. Refer to qualified personnel for servicing. Opening voids warranty and could result in damage to the equipment and possibly even personal injury.

CONTROL PANEL MOUNTING

The control panel is to be mounted in an indoor area where the ambient temperature range will be 30 to 120°F (0 to 50°C) and less than 95% RH. Power Supply is to be 115 V (ac) +/- 10% 50/60 Hz 600 VA.

The installer must ensure that this control and its wiring are isolated and/or shielded from strong sources of electromagnetic noise. Conversely, this Class B digital apparatus complies with Part 15 of the FCC Rules and meets all requirements of the Canadian Interference-Causing Equipment Regulations. However, if this control does cause harmful interference to radio or television reception, which is determined by turning the control on and off, the user is encouraged to try and correct the interference by re-orienting or relocating the receiving antenna, relocating the receiver with respect to the control, and/or connecting the control to a different circuit from that to which the receiver is connected.

WARNING: The nonmetallic enclosure does not provide grounding between conduit connections. Use grounding type bushings and jumper wires as needed.

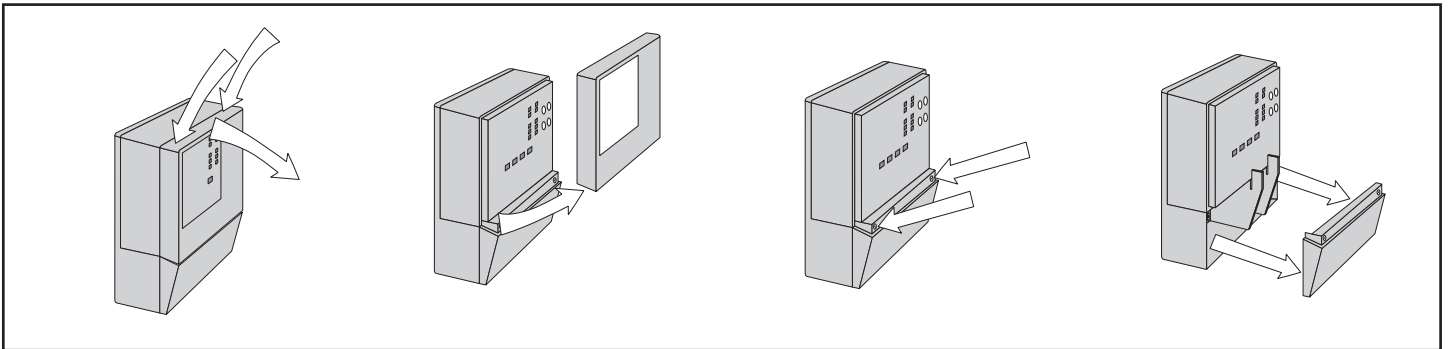

Press down at the fingertip grips on top of the front cover and pull out and down.

Lift the front cover up and away from the control.

Loosen the screws at the front of the wiring cover.

The wiring cover pulls straight out from the wiring chamber.

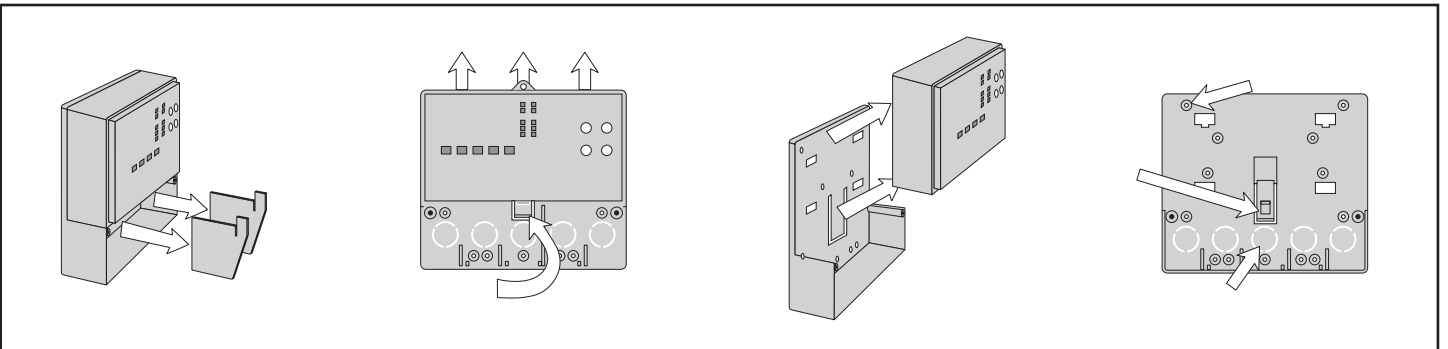

Remove the safety dividers from the wiring chamber by pulling them straight out of their grooves.

Press the control release clip on the base inside the wiring chamber and slide the control upwards.

The control lifts up and away from the base.

The base is ready for mounting.

The control can be mounted on a standard DIN rail. First remove the control from its base and then, using the hooks and spring clip on the back of the control, mount it onto the DIN rail. This will be a popular option for those who prefer to mount the control inside a larger electrical panel.

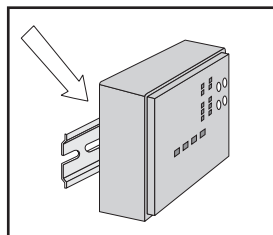

The wiring can enter the bottom or the back of the enclosure. Knock-outs provided in the base allow the wiring to be run in conduit up to the enclosure. The base also has holes that line up with the mounting holes of most common electrical boxes.

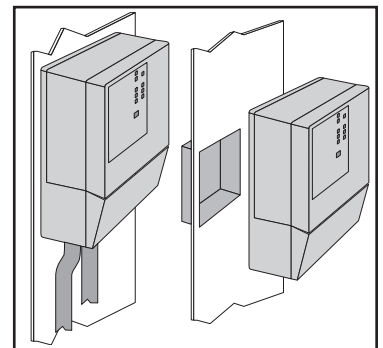

INSTALLING THE SENSORS

OUTDOOR SENSOR SLANT/FIN P/N 339070

MOUNTING THE SENSOR

Note: The temperature sensor (thermistor) is built into the enclosure.

- Remove the screw and pull the front cover off the sensor enclosure.
- The enclosure can either be mounted directly onto a wall or a 2" x 4" electrical box. When it is wall mounted, the wiring should enter through the back or bottom of the enclosure. Do not mount the enclosure with the conduit knockout facing upwards as rain could enter the enclosure and damage the sensor.

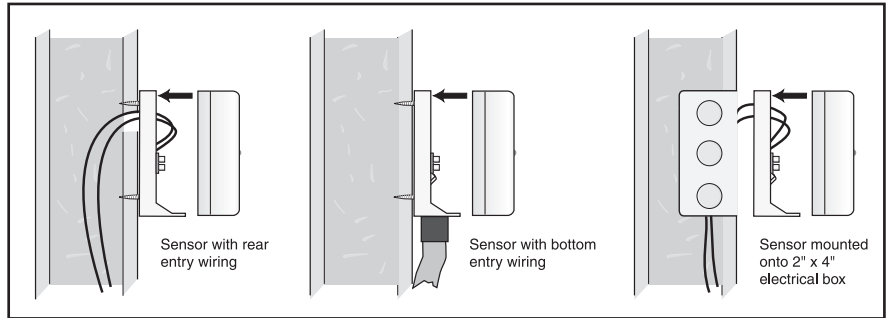

- In order to prevent heat transmitted through the wall from affecting the sensor reading, it may be necessary to install an insulating barrier behind the enclosure.
- The sensor should be mounted on a northern wall of the building. It should not be exposed to heat sources such as ventilation or window openings. **Caution:** If sunlight strikes the sensor enclosure or the surface area surrounding it, the system will provide water temperatures that are not high enough to meet the demand.
- It should be installed at an elevation above the ground that will prevent accidental damage or tampering.

WIRING AND TESTING THE SENSOR

- Connect 18 AWG or similar wire to the two terminals provided in the enclosure and run the wires from the sensor to the control. **Do not run the wires close to and parallel to telephone or power cables.** If the sensor wires are located in an area with strong sources of electromagnetic interference (EMI), shielded cable or twisted pair should be used or the wires can be run in a grounded metal conduit. If using shielded cable, the shield wire should be connected to the Com Sen terminal on the control and not to earth ground.
- Follow the sensor testing instruction that follows and connect the wires to the control.
- Replace the front cover of the sensor enclosure.

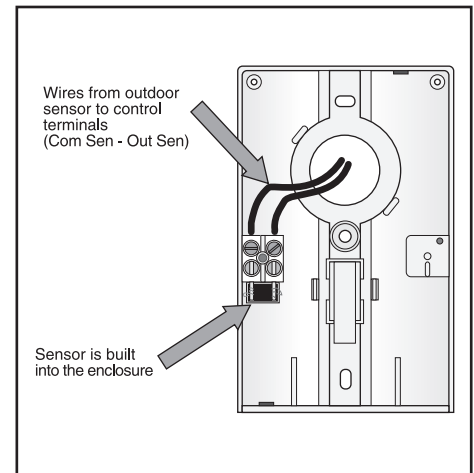

UNIVERSAL SENSORS

MOUNTING THE SENSOR SF P/N 339071

Note: These sensors are designed to mount in an immersion well or on a pipe.

For example - If a sensor is mounted onto a 1" type L copper pipe, there is approximately an 8 second delay between a sudden change in water temperature and the time the sensor measures the change. This delay increases considerably when steel pipe is used.

It is strongly recommended that an immersion well be used, especially when steel pipe of greater than 1-1/4" is used and also when large diameter pipes are used and fluid stratification is probable.

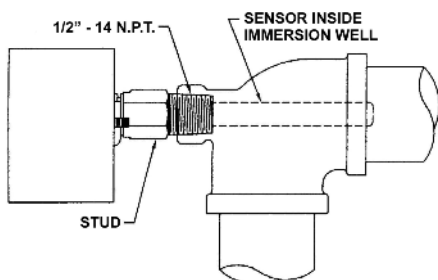

Sensor Mounted In Immersion Well
SLANT/FIN P/N 410569

The Universal Sensor can be strapped directly to the pipe using the cable tie provided. Insulation should be placed around the sensor to reduce the effect of air currents on the sensor measurement. The flat portion of the sensor should be mounted against the pipe.

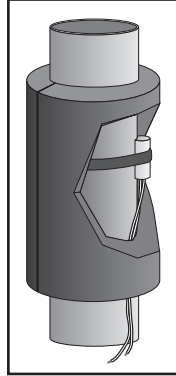

The Universal Sensor should be placed downstream of a pump or after an elbow or similar fitting. This is especially important if large diameter pipes are used as the thermal stratification within the pipe can result in erroneous sensor readings. Proper sensor location requires that the fluid is thoroughly mixed within the pipe before it reaches the sensor.

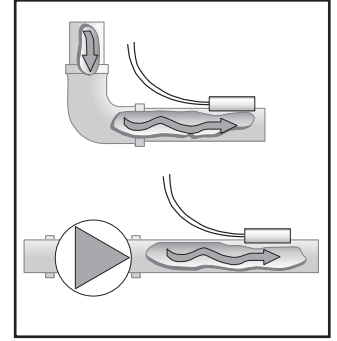

WIRING AND TESTING THE SENSOR

WARNING: Do not run sensor wires close to and parallel to telephone or power cables. If the sensor wires are located in an area with strong sources of electromagnetic interference, shielded cable or twisted pair should be used or the wires can be run in a grounded metal conduit. If using shielded cable, the shield wire should be connected to the Com Sen terminal on the control and not to earth ground.

- It is necessary to connect 18 AWG wire to the two sensor wires. Wire nuts can be used to hold the wires together.
- Follow the sensor testing instructions that follow and then connect the wires to the control.

SENSOR TESTING INSTRUCTIONS

A good quality test meter capable of measuring up to 5,000 k Ω (1 k Ω = 1000 Ω) is required to measure the sensor resistance. In addition to this, the actual temperature must be measured with either a good quality digital thermometer, or if a thermometer is not available, a second sensor can be placed alongside the one to be tested and the readings compared.

First measure the temperature using the thermometer and then measure the resistance of the sensor at the control. The wires from the sensor must not be connected to the control while the test is performed. Using the chart below, estimate the temperature measured by the sensor. The sensor and thermometer readings should be close. If the test meter reads a very high resistance, there may be a broken wire, a poor wiring connection or a defective sensor. If the resistance is very low, the wiring may be shorted, there may be moisture in the sensor or the sensor may be defective. To test for a defective sensor, measure the resistance directly at the sensor location.

Do not apply voltage to a sensor at any time as damage to the sensor may result.

Temperature		Resistance	Temperature		Resistance	Temperature		Resistance	Temperature		Resistance
°F	°C	□	°F	°C	□	°F	°C	□	°F	°C	□
-50	-46	490,813	20	-7	46,218	90	32	7,334	160	71	1,689
-45	-43	405,710	25	-4	39,913	95	35	6,532	165	74	1,538
-40	-40	336,606	30	-1	34,558	100	38	5,828	170	77	1,403
-35	-37	280,279	35	2	29,996	105	41	5,210	175	79	1,281
-30	-34	234,196	40	4	26,099	110	43	4,665	180	82	1,172
-25	-32	196,358	45	7	22,763	115	46	4,184	185	85	1,073
-20	-29	165,180	50	10	19,900	120	49	3,760	190	88	983
-15	-26	139,402	55	13	17,436	125	52	3,383	195	91	903
-10	-23	118,018	60	16	15,311	130	54	3,050	200	93	829
-5	-21	100,221	65	18	13,474	135	57	2,754	205	96	763
0	-18	85,362	70	21	11,883	140	60	2,490	210	99	703
5	-15	72,918	75	24	10,501	145	63	2,255	215	102	648
10	-12	62,465	80	27	9,299	150	66	2,045	220	104	598
15	-9	53,658	85	29	8,250	155	68	1,857	225	107	553

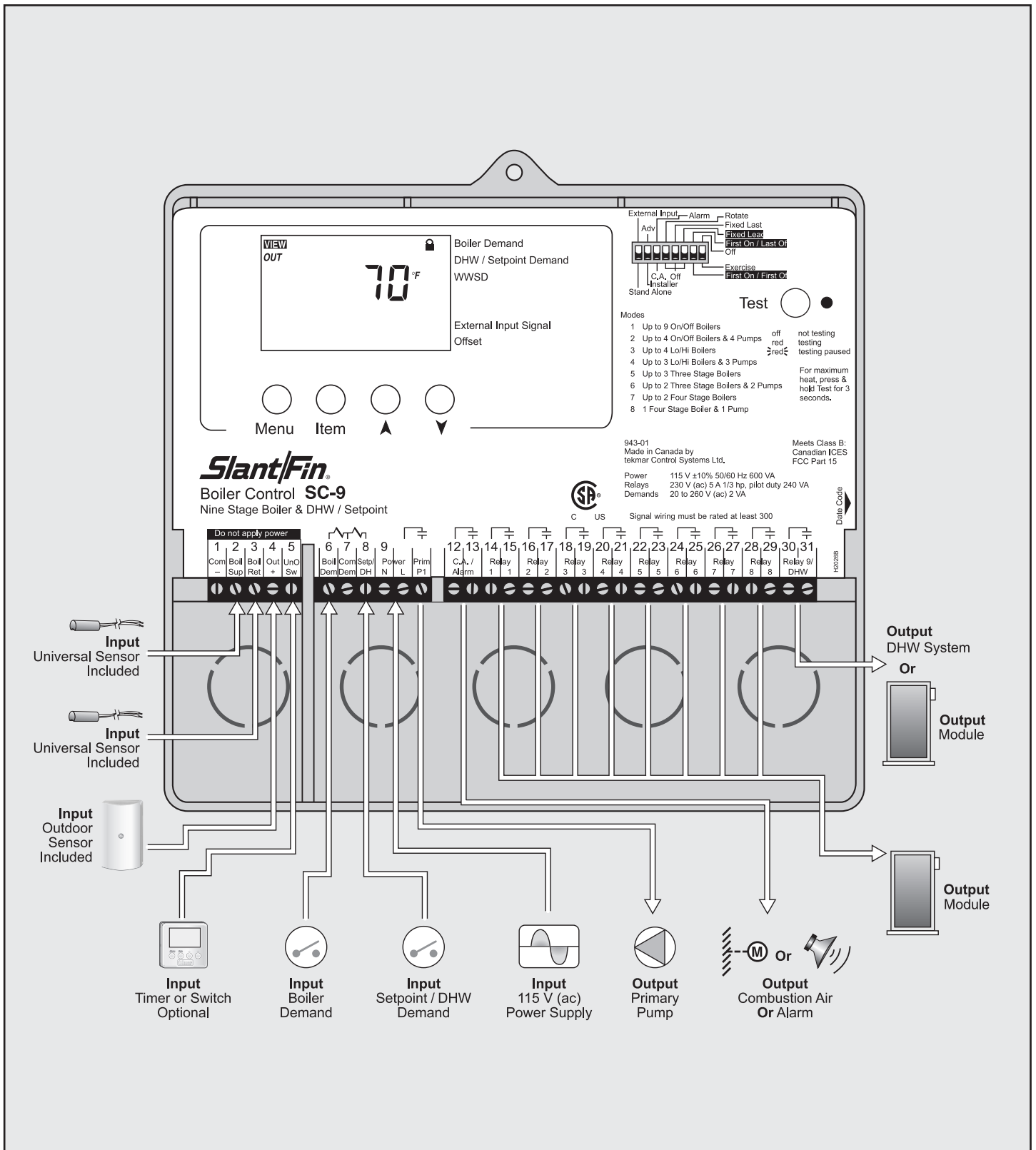

WIRING THE SYSTEM

Use one of the following wiring diagrams to wire your system, along with the appropriate diagram on **page 10**.

1. Gas fired - space heating only
2. Gas fired - space heating with DHW
3. Oil fired - space heating only
4. Oil fired - space heating with DHW

If using MM 750P-MT120 L.W.C.O. use **Figure C6** on page 10 to wire the control

1. Gas fired - space heating only

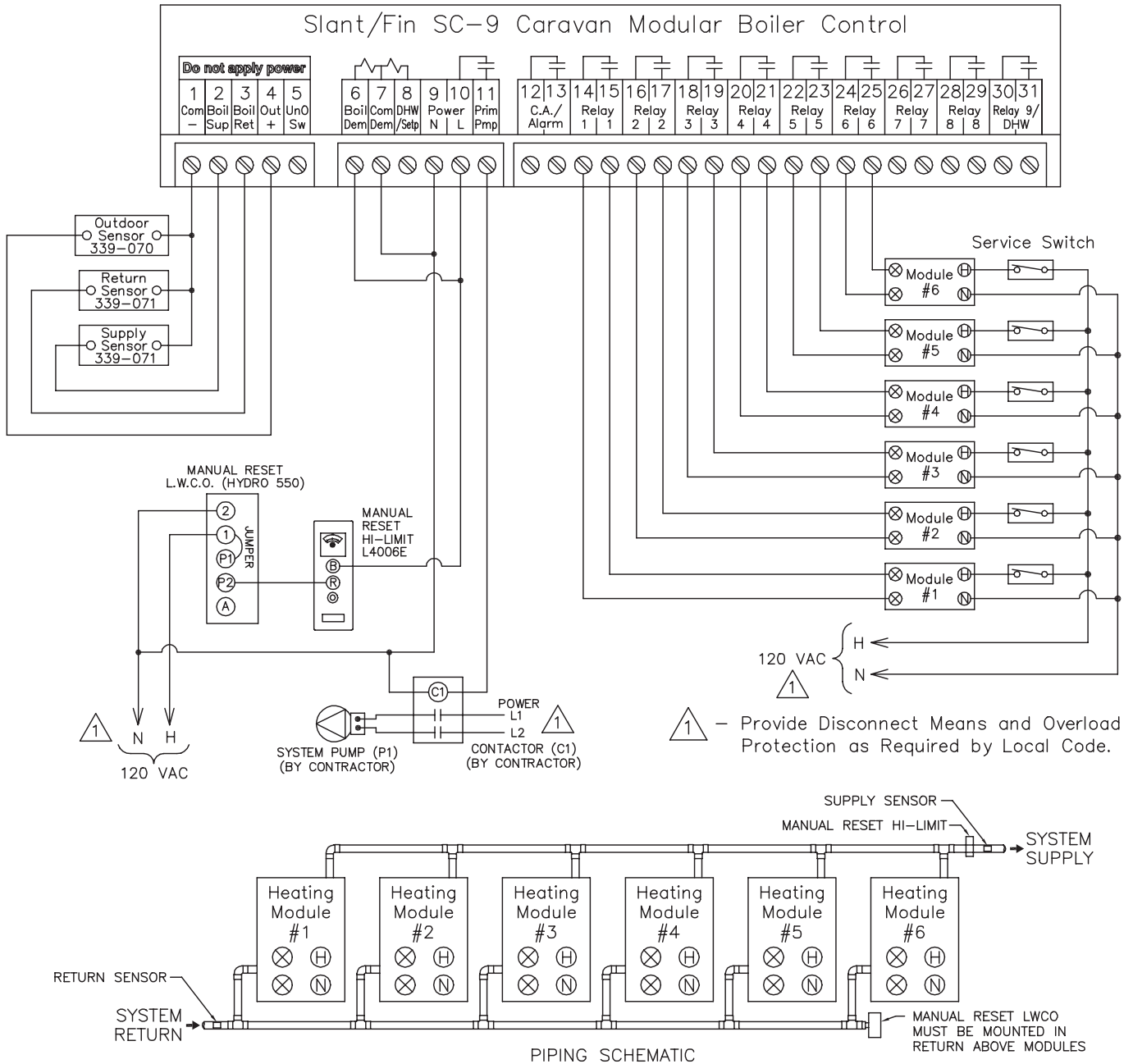

NOTE: For boiler termination wiring at modules, see **page 10**

2. Gas fired - space heating with DHW

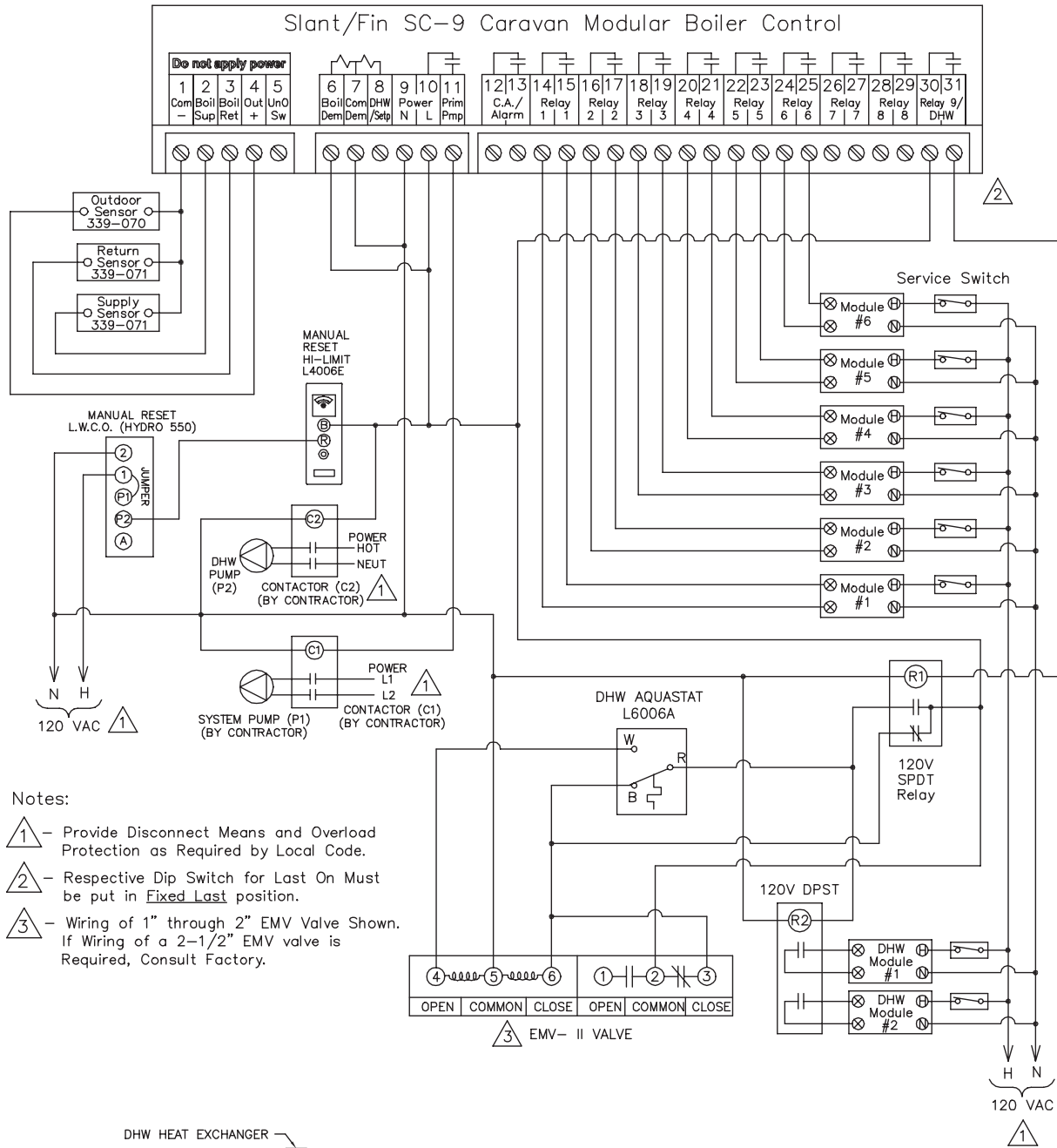

Notes:

- 1 - Provide Disconnect Means and Overload Protection as Required by Local Code.
- 2 - Respective Dip Switch for Last On Must be put in **Fixed Last** position.
- 3 - Wiring of 1" through 2" EMV Valve Shown. If Wiring of a 2-1/2" EMV valve is Required, Consult Factory.

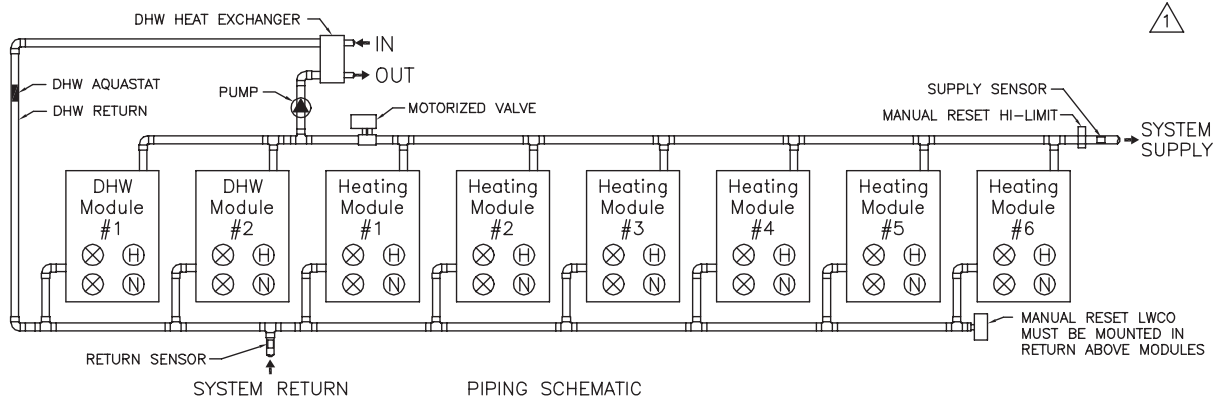

NOTE: For boiler termination wiring at modules, see page 10

3. Oil fired - space heating only

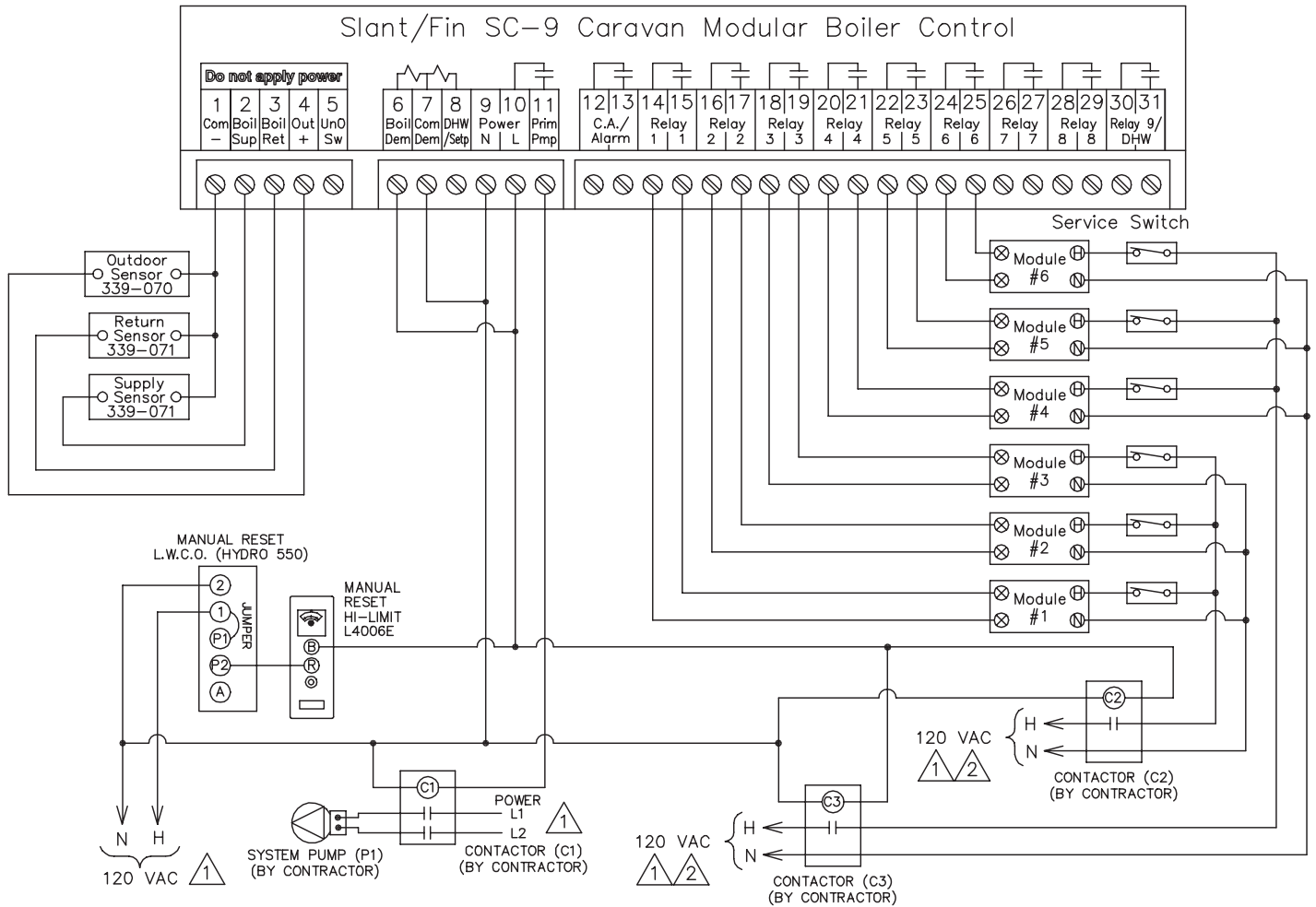

Notes:

- ① - Provide Disconnect Means and Overload Protection as Required by Local Code.
- ② - Single Pole Contactors Shown, Multiple Pole Contactor May be Used. Each Burner is Rated @ 6 FLA, Size Contactor Accordingly.

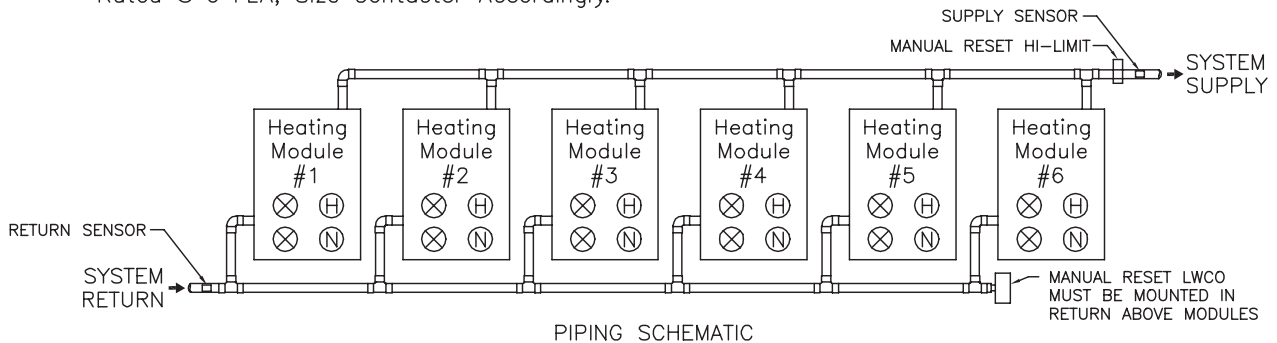

NOTE: For boiler termination wiring at modules, see page 10

4. Oil fired - space heating with DHW

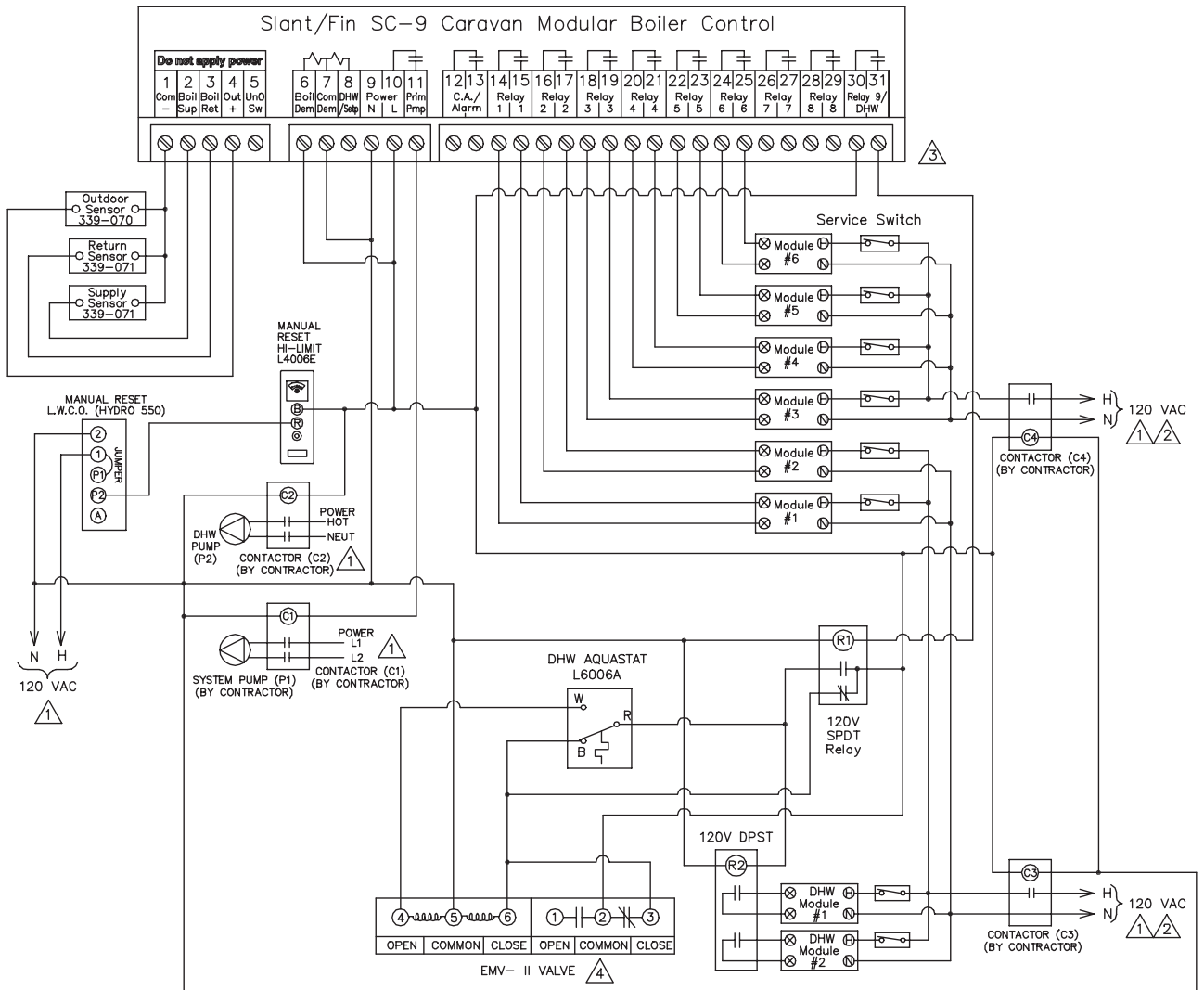

- Notes:
- ① - Provide Disconnect Means and Overload Protection As Required by Local Code.
 - ② - Single Pole Contactors Shown, Multiple Pole Contactor May be Used. Each Burner Is Rated @ 6 FLA, Size Contactor Accordingly.
 - ③ - Respective Dip Switch for Last On Must be put in Fixed Last Position.
 - ④ - Wiring of 1" through 2" EMV Valve Shown. If Wiring of a 2-1/2" EMV Valve is Required, Consult Factory.

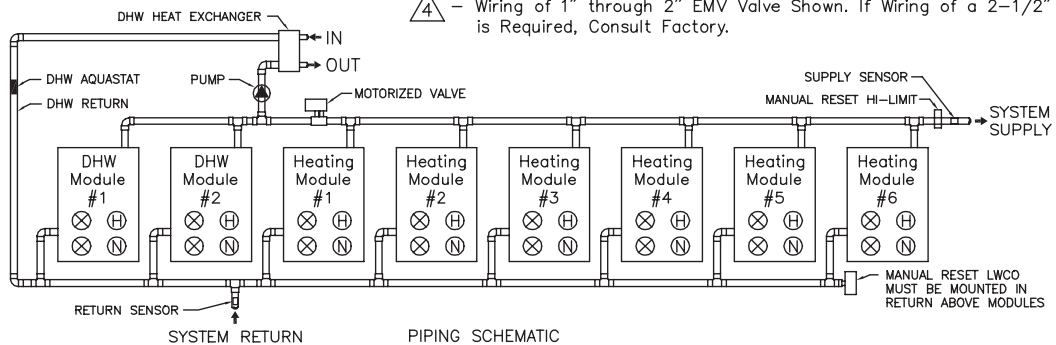

NOTE: For boiler termination wiring at modules, see page 10

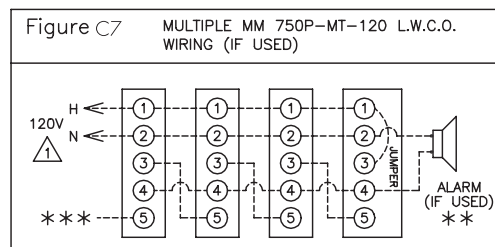
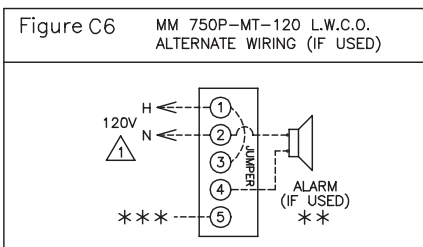
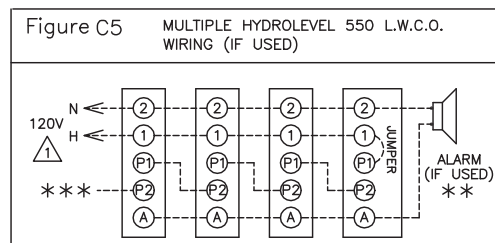
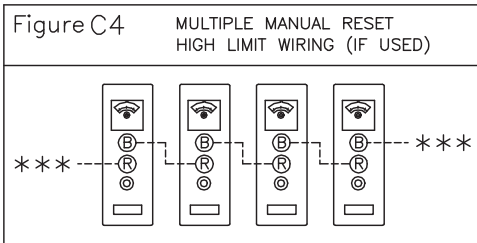
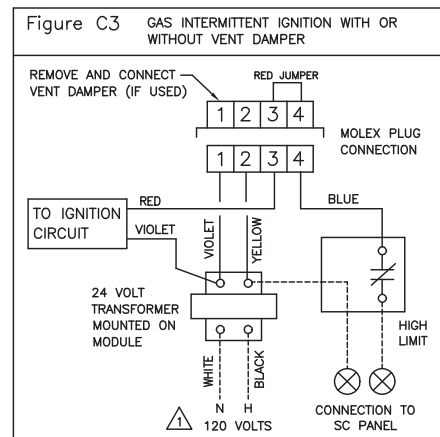
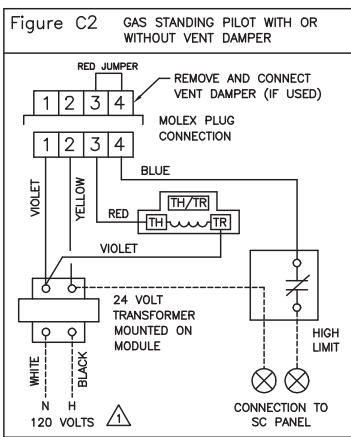
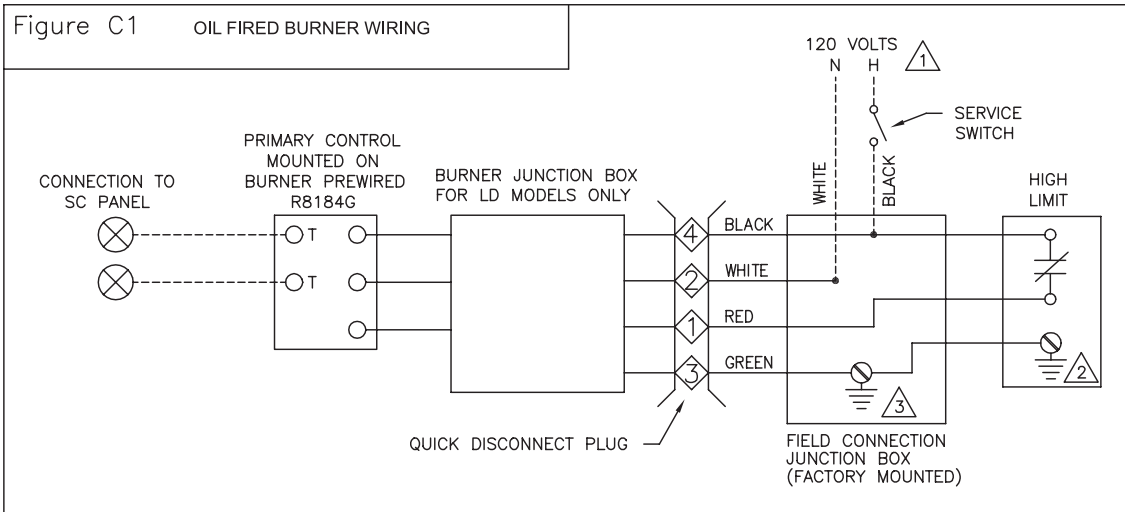

- ① - PROVIDE DISCONNECT MEANS AND OVERLOAD PROTECTION AS REQUIRED BY LOCAL CODE.
- ② - CONTROL CASE MUST BE CONNECTED TO EARTH GROUND. USE GROUND SCREW PROVIDED.
- ③ - GROUNDING CONDUCTOR: TWO GREEN GROUND WIRES ARE FACTORY CONNECTED TO THE GREEN GROUND SCREW IN THIS BOX. FIELD WIRE A GROUNDED CONDUCTOR TO THIS SCREW TOGETHER WITH THE TWO GREEN FACTORY CONNECTED GREEN GROUND WIRES.
- ** - OPTIONAL ALARM CIRCUIT BY CONTRACTOR.
- *** - REFER TO SC-3 OR SC-9 WIRING DIAGRAM FOR PROPER WIRE CONNECTION.

LEGEND:

- FIELD WIRING
- FACTORY WIRING

DISPLAY:

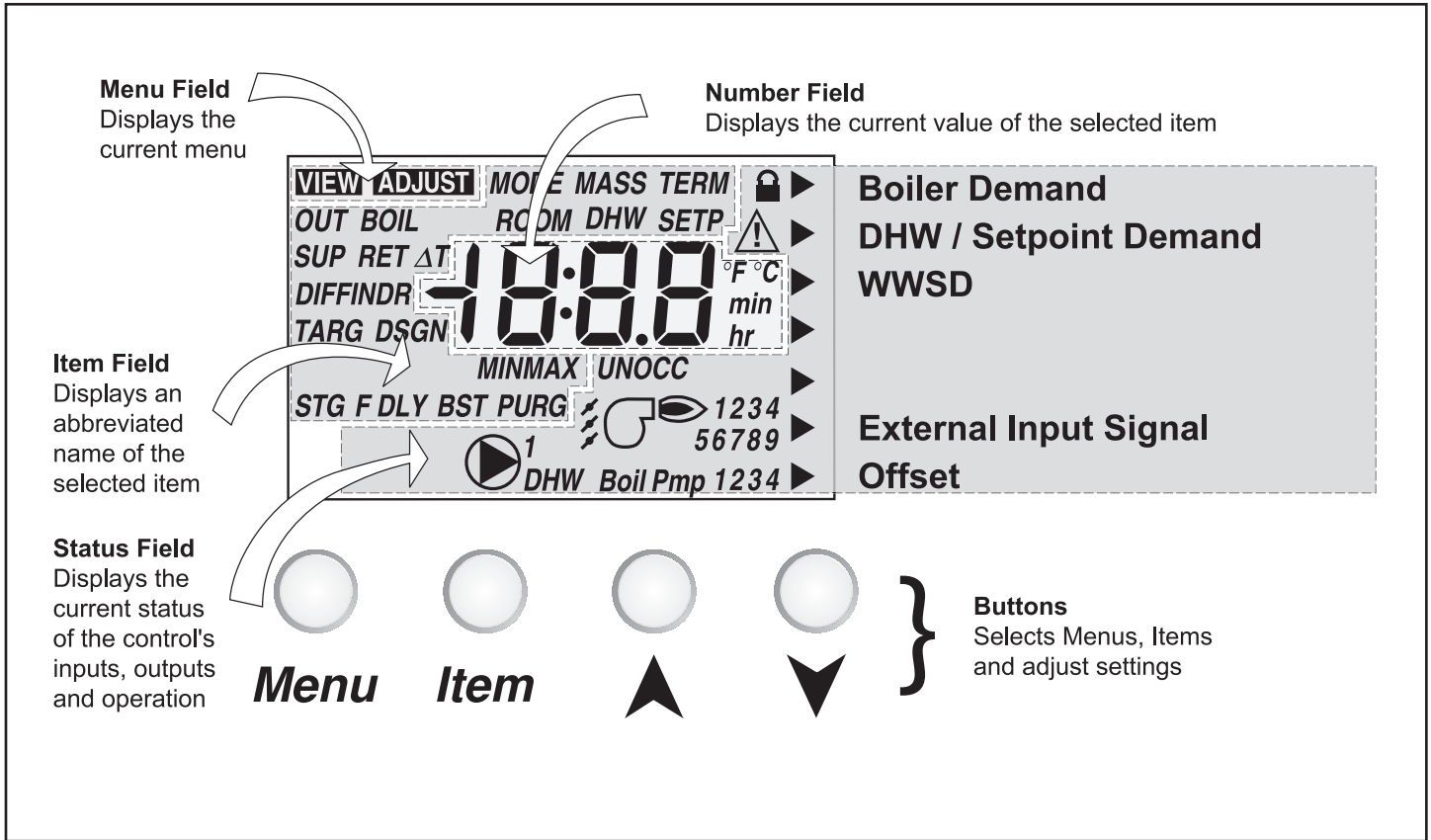

Symbol Description

<p>Stage Displays which stage relays are turned on.</p>	<p>UNOCC</p> <p>UnOccupied Schedule Displays when the control is in UnOccupied Mode.</p>
<p>Primary Pump Displays when the primary pump relay is turned on.</p>	<p>OCC</p> <p>Occupied Schedule Displays when the control is in Occupied Mode.</p>
<p>Combustion Air Damper Displays when the Combustion Air Damper relay is turned on</p>	<p>Installer Access Level Displays when the Installer/Advanced Dip switch is set to Installer</p>
<p>Delta T The current difference between the supply and return temperatures.</p>	<p>Pointer Displays the control operation as indicated by the text.</p>
<p>°F °C min hr</p> <p>°F, °C, min, hr Units of measurement.</p>	<p>Warning/Alarm Displays when an error exists or the alarm relay is turned on.</p>

User Interface

The control uses a Liquid Crystal Display (LCD) as the method of supplying information. You use the LCD in order to setup and monitor the operation of your system. The control has four push buttons (Menu, Item, s, t) for selecting and adjusting settings. As you program your control, record your settings in the ADJUST menu table which is found in the second half of this brochure.

Menu

All of the items displayed by the control are organized into two menus. These menus are listed on the top left hand side of the display (Menu Field). To select a menu, use the Menu button. By pressing and releasing the Menu button, the display switches between the two menus. Once a menu is selected, there will be a group of items that can be viewed within the menu.

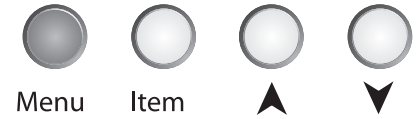

Item

The abbreviated name of the selected item will be displayed in the item field of the display. To view the next available item, press and release the Item button. Once you have reached the last available item in a menu, pressing and releasing the Item button will return the display to the first item in the selected menu.

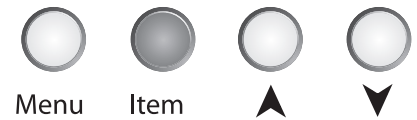

Adjust

To make an adjustment to a setting in the control, begin by selecting the ADJUST menu using the Menu button. Then select the desired item using the Item button. Finally, use the s, and / or t button to make the adjustment.

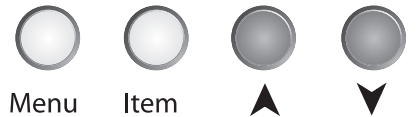

Additional information can be gained by observing the Status field of the LCD. The status field will indicate which of the control's outputs are currently active. Most symbols in the status field are only visible when the VIEW menu is selected.

SELECT SYSTEM TYPE:

- A. Space Heating ONLY with Outdoor Reset (Most systems) Page 13
- B. Space Heating ONLY with Setpoint Control Page 18
- C. Space Heating with DHW with Outdoor Reset Page 19
- D. Space Heating with DHW with Setpoint Control Page 20

To set up the control, go to the appropriate page for your system.

If your system is different than the above, call the Slant/Fin technical services group at 800-873-4346 to determine if the control can accommodate it.

A. SPACE HEATING ONLY WITH OUTDOOR RESET

CONTROL SET UP

DIP SWITCH SETTINGS:

General

The DIP switch settings on the control are very important and should be set to the appropriate settings prior to making any adjustments to the control through the User Interface. The DIP switch settings change the items that are available to be viewed and / or adjusted in the User Interface.

If a DIP switch is changed while the control is powered up, the control responds to the change in setting by returning the display to the VIEW menu.

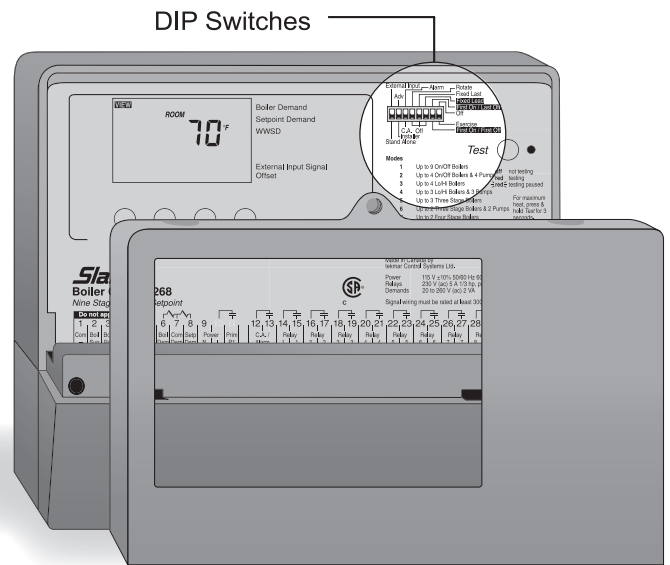

External Input / Stand Alone

The External Input / Stand Alone DIP switch selects whether a Slant/Fin Outdoor Sensor 339070 or an external 0-10 V (dc) input signal is to be connected to the Com - and the Out + terminals (1 and 4).

Set to Stand Alone

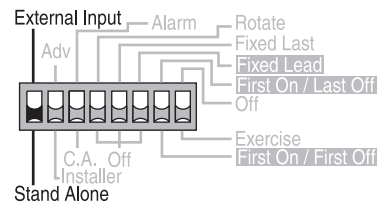

Advanced / Installer

The Adv / Installer DIP switch selects the access level of the control. In the Installer access level, a limited number of items may be viewed and / or adjusted. In the Advanced access level, all items may be viewed and / or adjusted.

Set to Installer

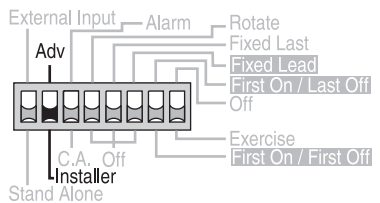

Alarm / Combustion Air

The Alarm/Combustion Air DIP switch selects whether a combustion air damper or alarm device is to be connected to the C.A. / Alarm terminals (12 and 13).

Set to proper position. Ignore if neither is present.

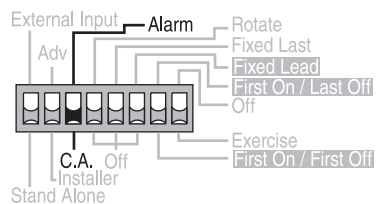

Rotate / Off

The Rotate / Off DIP switch selects whether or not the control is to provide Equal Run Time Rotation of the boiler stages. If the switch is set to Rotate, the stages will be rotated accordingly. If the switch is set to Off, the firing sequence is fixed starting with the lowest stage to the highest stage.

We recommend that it be set to Rotate for most systems

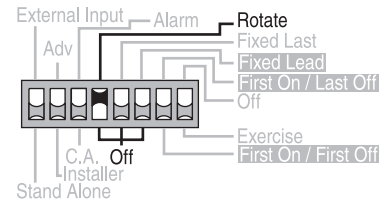

Fixed Last / Off

The Fixed Last / Off DIP switch selects whether or not the last boiler is to be included in the rotation sequence. If the DIP switch is set to Fixed Last, the last boiler is always the last to fire. This DIP switch is only active when the Rotate/Off DIP switch is set to Rotate.

We recommend that it be set to Off for most systems.

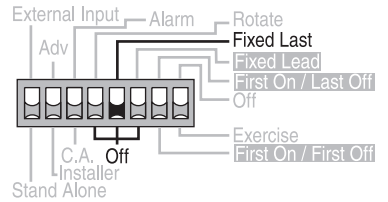

Fixed Lead / Off

The Fixed Lead / Off DIP switch selects whether or not the first boiler is to be included in the rotation sequence. If the DIP switch is set to Fixed Lead, the first boiler is always the first to fire. This DIP switch is only active when the Rotate/Off Dip switch is set to Rotate.

We recommend that it be set to Off for most systems. Unusually long breeching from first boiler to chimney may require that it be set to Fixed Lead.

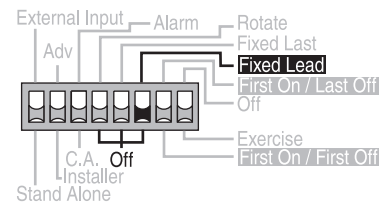

First On / Last Off or First On / First Off

The First On / Last Off or First On / First Off DIP switch selects whether the first boiler is the first to stage on and the last to stage off or the first to stage on and the first to stage off. This DIP switch is only active when the Rotate / Off DIP switch is set to Rotate and the Fixed Lead / Off DIP switch is set to Fixed Lead.

We recommend that it be set to First On/First Off for most systems.

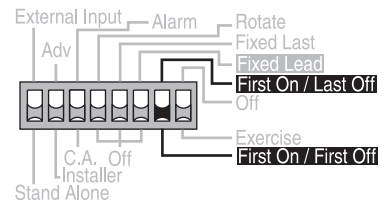

Off / Exercise

The Off / Exercise DIP switch selects whether or not the control is to exercise the primary pump and boiler pumps. If the DIP switch is set to Exercise, the pumps are operated for 10 seconds after every three days of inactivity.

We recommend that it be set to Exercise for most systems.

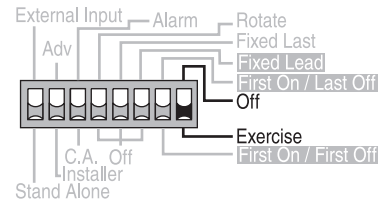

THE CONTROL MUST BE ADJUSTED FOR YOUR APPLICATION.

IF ANY OF THE DEFAULT SETTINGS DO NOT SUIT YOUR APPLICATION, GO TO THE ADJUSTING SECTION THAT FOLLOWS EACH FUNCTION AND WRITE IN THE DESIRED SETTING IN THE SQUARE BOX PROVIDED FOR THAT FUNCTION. THEN PERFORM THE ADJUSTMENT AS LISTED.

THESE INSTRUCTIONS ARE WRITTEN WHERE EACH FUNCTION IS ADJUSTED IN A “STAND ALONE” MANNER MEANING YOU ARE PROGRAMMING THAT ONE FUNCTION ONLY. IF YOU WANT TO PROGRESSIVELY GO THROUGH EACH STEP, JUST SKIP THE INSTRUCTIONS WRITTEN IN *ITALIC LETTERS* FOR EACH STEP AND PROGRAM THE CONTROL PROGRESSIVELY THROUGH EACH FUNCTION.

IT IS BEST IF YOU TAKE A FEW MINUTES TO GO THROUGH THE ENTIRE LIST OF FUNCTIONS AND ENTER ANY NEW SETTINGS THAT ARE APPROPRIATE FOR YOUR INSTALLATION. WHEN FINISHED, GO TO THE CONTROL AND ADJUST ONLY THOSE FUNCTIONS THAT HAVE A NEW SETTING LISTED.

PROGRAMMING For Most Applications

Programming sequence for most applications is covered in this section. This is followed when the Advanced/Installer DIP switch is set to Installer.

Set Adv/Installer DIP switch to Installer

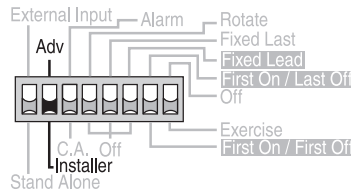

See Page 17 for instructions to program control using °C

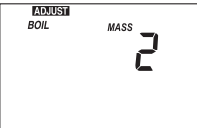
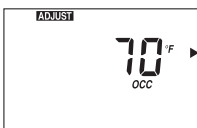
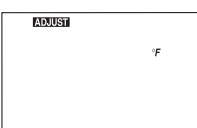

Display	Description	Default Setting	New Setting
	<p>Room Occupied - The desired room air temperature during the occupied period.</p> <p>Press the Menu button until ADJUST is visible on the top line of the display. Press the Item button until ROOM appears above the temperature readout and OCC is flashing below it. Use the up and down arrow buttons to change to the desired reading. This item is only available if the External Input/Stand Alone DIP switch is set to Stand Alone.</p> <p>Range Available: 35° to 100°F (2° to 38°C)</p>	<p>70° F (21° C)</p>	
	<p>Room Unoccupied - The desired room air temperature during the unoccupied period.</p> <p><i>Press the Menu button until ADJUST is visible on the top line of the display.</i> Press the Item button until ROOM appears above the temperature readout and UNOCC is flashing below it. Use the up and down arrow buttons to change to the desired reading. This item is only available if the External Input/Stand Alone DIP switch is set to Stand Alone.</p> <p>Range Available: 35° to 100°F (2° to 38°C)</p>	<p>65° F (18.5° C)</p>	
	<p>Boiler 1 - Selects whether or not module 1 is operational - Au (auto) or OFF</p> <p>DO NOT CHANGE</p> <p><i>Press the Menu button until ADJUST is visible on the top line of the display.</i> Press Item button until BOIL to the left of, and above Au and 1 is below it. Use the up and down arrow buttons to change setting. However for the setting of Au should be retained, do not change to OFF.</p>	<p>Au</p>	

Display	Description	Default Setting	New Setting
	<p>Boiler 2 - Selects whether or not module 2 is operational - Au (auto) or OFF DO NOT CHANGE</p> <p>Press the Menu button until ADJUST is visible on the top line of display. Press the Item button until BOIL to the left of, and above Au and 2 is below it. Use the up and down arrow buttons to change setting. However, the setting of Au should be retained, do not change to OFF.</p>	Au	
	<p>Boiler 3 - Selects whether or not module 3 is operational - Au (auto) or OFF</p> <p>If you do not have 3 or more boiler modules Press the Menu button until ADJUST is visible on the top line of the display. Press the Item button until BOIL to the left of, and above Au and 3 is below it. Use the up and down arrow buttons to change to OFF.</p>	Au	
	<p>Boiler 4 - Selects whether or not module 4 is operational - Au (auto) or OFF</p> <p>If you do not have 4 or more boiler modules Press the Menu button until ADJUST is visible on the top line of the display. Press the Item button until BOIL to the left of, and above Au and 4 is below it. Use the up and down arrow buttons to change to OFF.</p>	Au	
	<p>Boiler 5 - Selects whether or not module 5 is operational - Au (auto) or OFF</p> <p>If you do not have 5 or more boiler modules Press the Menu button until ADJUST is visible on the top line of the display. Press the Item button until BOIL to the left of, and above Au and 5 is below it. Use the up and down arrow buttons to change to OFF.</p>	Au	
	<p>Boiler 6 - Selects whether or not module 6 is operational - Au (auto) or OFF</p> <p>If you do not have 6 or more boiler modules Press the Menu button until ADJUST is visible on the top line of the display. Press the Item button until BOIL to the left of, and above Au and 6 is below it. Use the up and down arrow buttons to change to OFF.</p>	Au	
	<p>Boiler 7 - Selects whether or not module 7 is operational - Au (auto) or OFF</p> <p>If you do not have 7 or more boiler modules Press the Menu button until ADJUST is visible on the top line of the display. Press the Item button until BOIL to the left of, and above Au and 7 is below it. Use the up and down arrow buttons to change to OFF.</p>	Au	
	<p>Boiler 8 - Selects whether or not module 8 is operational - Au (auto) or OFF</p> <p>If you do not have 8 or more boiler modules Press the Menu button until ADJUST is visible on the top line of the display. Press the Item button until BOIL to the left of, and above Au and 8 is below it. Use the up and down arrow buttons to change to OFF.</p>	Au	
	<p>Boiler 9 - Selects whether or not module 9 is operational - Au (auto) or OFF</p> <p>If you do not have 9 or more boiler modules Press the Menu button until ADJUST is visible on the top line of the display. Press the Item button until BOIL to the left of, and above Au and 9 is below it. Use the up and down arrow buttons to change to OFF.</p>	Au	
	<p>Outdoor design - The design outdoor temperature used in the heat loss calculations for the heating system.</p> <p>Press the Menu button until ADJUST is visible on the top line of the display. Press the Item button until OUT and DSGN appear. Use the up and down arrow buttons to change to the desired setting. Range Available: -60° to 45°F (-51° to 7°C)</p>	10°F (-12°C)	

Display	Description	Default Setting	New Setting
	<p>Boiler Mass - This inputs the thermal mass characteristics of the boiler modules.</p> <p>Press the Menu button until ADJUST is visible on the top line of the display. Press the Item button until BOIL is below ADJUST and MASS is to the right of ADJUST. Default is 2 with 1 being low mass and 3 being high mass. For Slant/Fin boilers we recommend you retain the default setting of 2.</p>	2	
	<p>WWSD Occupied - The systems warm weather shut down temperature during the occupied period.</p> <p>Press the Menu button until ADJUST is visible on the top line of the display. Press the Item button until OCC appears. Use the up and down arrow buttons to change to the desired temperature. Range Available: 35° to 100°F (2° to 38°C or OFF)</p>	70°F (21°C)	
	<p>Units - The units of measure that all of the temperatures are to be displayed by the control</p> <p>Press the Menu button until ADJUST is visible on the top line of the display. Press the Item button until °F or °C appears. Use the up and down arrow buttons to change to the desired setting - °F or °C</p>	°F	

NOTE: When you press **ITEM** button again you will go to the beginning of the sequence

Listed below are additional settings that are frequently changed from the factory default setting to a new setting. These adjustments are made with the **Installer/Adv DIP** switch in the **Adv** setting. You will progress through a series of steps before you arrive at the steps that you want to adjust. Please be careful and do not change the settings on any of the series of steps you pass through. If you do make a mistake and change the setting on any of these steps we have listed the factory default settings in the back of this manual. You can adjust that step accordingly.

Display	Description	Default Setting	New Setting
	<p>Boiler Design - The design supply water temperature used in the design of the system.</p> <p>Move the Adv / Installer DIP switch to the Adv position <i>temporarily</i>. Press the Menu button until ADJUST is visible on the top line of the display. Press the Item button until BOIL-DSGN appears. Use the up and down arrow buttons to change to the desired temperature. Move the Adv / Installer DIP switch back to the Installer position. Range Available: 70° to 220°F</p>	180°F (82°C)	
	<p>Boiler Maximum - The maximum allowed boiler target temperature</p> <p>Move the Adv / Installer DIP switch to the Adv position <i>temporarily</i>. Press the Menu button until ADJUST is visible on the top line of the display. Press the Item button until BOIL-MAX appears. Use the up and down arrow buttons to change to the desired temperature. Move the Adv / Installer DIP switch back to the Installer position. Range Available: 120° to 225°F or OFF</p>	200°F (93.5°C)	

B. SPACE HEATING ONLY WITH SETPOINT CONTROL

DIP SWITCH SETTINGS:

General

The DIP switch settings on the control are very important and should be set to the appropriate settings prior to making any adjustments to the control through the User Interface. The DIP switch settings change the items that are available to be viewed and / or adjusted in the User Interface.

If a DIP switch is changed while the control is powered up, the control responds to the change in setting by returning the display to the VIEW menu.

With the exception of **Adv / Installer DIP** switch, the DIP switch settings are the same as in Section A “Space Heating with Outdoor Reset”.

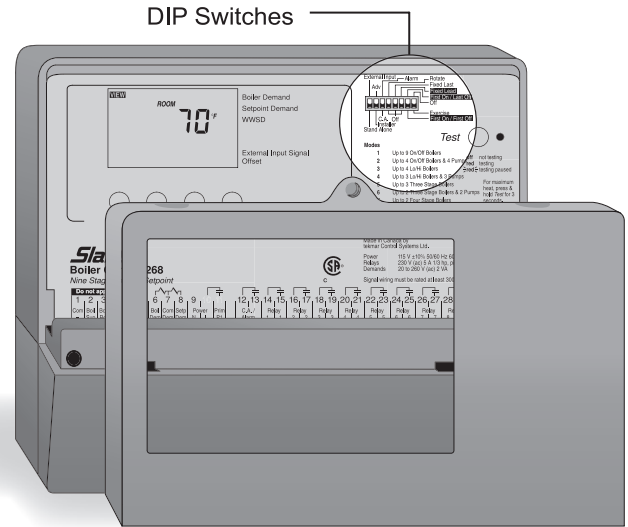

STEP 1: With the exception of **Adv / Installer DIP** switch, all DIP switches should be set the same as in Section A, page 13, - “SPACE HEATING WITH OUTDOOR RESET”.

STEP 2: The following adjustments should be done after you have programmed Section A - “SPACE HEATING WITH OUTDOOR RESET”.

STEP 3: Program the following steps.

Display	Description	Default Setting	New Setting
	<p>X Outdoor Design - For Setpoint Operation MUST be adjusted.</p> <p>Move the Adv / Installer DIP switch to Installer. Press the Menu button until ADJUST is visible on the top line of the display. Press the Item button until OUT and DSGN appear. Use the up and down arrow buttons to change the setting to 45°F.</p> <p>Range Available: -60° to 45°F (-51° to 7°C)</p>	<p>10°F (12°C)</p>	<p>45°F (7°C)</p>
	<p>Boiler Design - The design supply water temperature used in the design of the system. Set at least 10°F above Boiler Minimum setting.</p> <p>Move the Adv / Installer DIP switch to the Adv position temporarily. Press the Menu button until ADJUST is visible on the top line of the display. Press the Item button until BOIL-DSGN appears. Use the up and down arrow buttons to change to the desired temperature. Move the Adv / Installer DIP switch back to the Installer position.</p> <p>Range Available: 70° to 220°F (21° to 104°C)</p>	<p>180°F (82°C)</p>	
	<p>Boiler Minimum - The Setpoint Control Temperature</p> <p>Move the Adv / Installer DIP switch to the Adv position temporarily. Press the Menu button until ADJUST is visible on the top line of the display. Press the Item button until BOIL MIN appears. Use the up and down arrow buttons to change to the DESIRED SETPOINT temperature - 140°F or more. Move the Adv / Installer DIP switch back to the Installer position.</p> <p>Range Available: OFF, 80° - 180°F (OFF, 27° - 82°C)</p>	<p>140°F (60°C)</p>	
	<p>Boiler Maximum - The maximum allowed boiler target temperature. Set at least 10°F above Boiler Design setting.</p> <p>Move the Adv / Installer DIP switch to the Adv position temporarily. Press the Menu button until ADJUST is visible on the top line of the display. Press the Item button until BOIL-MAX appears. Use the up and down arrow buttons to change to the desired temperature. Move the Adv / Installer DIP switch back to the Installer position.</p> <p>Range Available: 120° to 225°F or OFF (49° to 107°C or OFF)</p>	<p>200°F (93.5°C)</p>	

Please contact the Slant/Fin Technical Services Department if you need another way.

Please note that other ways may require additional relays for circulators.

Slant/Fin Technical Service 1-800-873-4346

C. SPACE HEATING WITH DHW WITH OUTDOOR RESET

CONTROL SET UP

DIP SWITCH SETTINGS:

General

The DIP switch settings on the control are very important and should be set to the appropriate settings prior to making any adjustments to the control through the User Interface. The DIP switch settings change the items that are available to be viewed and / or adjusted in the User Interface.

If a DIP switch is changed while the control is powered up, the control responds to the change in setting by returning the display to the VIEW menu.

With the exception of **Rotate / OFF** and **Fixed Last / OFF** DIP switch. The DIP switch settings are the same as in System type A “Space Heating Only with Outdoor Reset”.

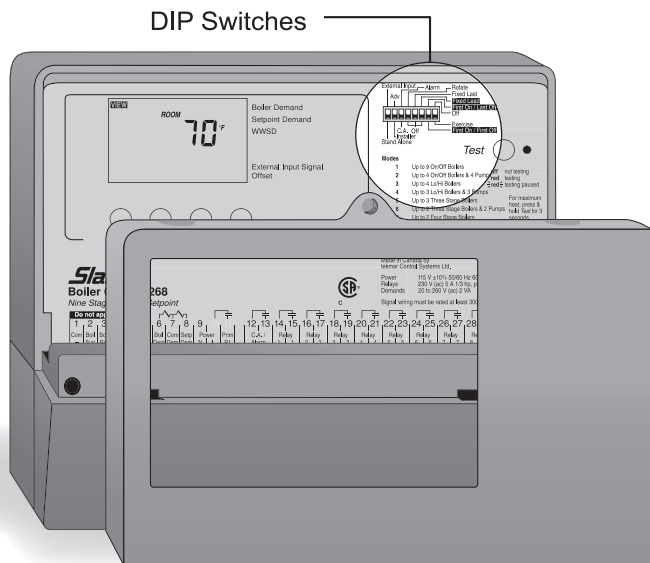

STEP 1: Set **Rotate / OFF** and **Fixed Last / OFF** DIP switches as follows.

Rotate / Off

The Rotate / Off DIP switch selects whether or not the control is to provide Equal Run Time Rotation of the boiler stages. If the switch is set to Rotate, the stages will be rotated accordingly. If the switch is set to Off, the firing sequence is fixed starting with the lowest stage to the highest stage.

Set to rotate

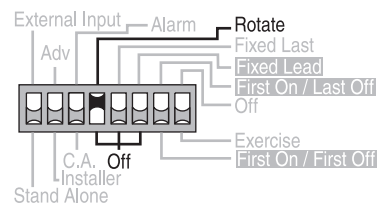

Fixed Last / Off

The Fixed Last / Off DIP switch selects whether or not the last boiler is to be included in the rotation sequence. If the DIP switch is set to Fixed Last, the last boiler is always the last to fire. This DIP switch is only active when the Rotate/Off DIP switch is set to Rotate.

Must be set to fixed last.

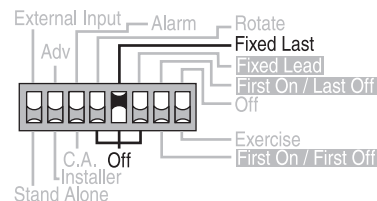

STEP 2: Program the control following programming steps in Section A, page 13, “Space Heating with Outdoor Reset”.

When the WWSD (Warm Weather Shut Down) temperature is reached the operation of DHW is still active. Control of the DHW modules during a demand for DHW by-passes the SC-9 Control.

D. SPACE HEATING WITH DHW WITH SETPOINT CONTROL

CONTROL SET UP

DIP SWITCH SETTINGS:

General

The DIP switch settings on the control are very important and should be set to the appropriate settings prior to making any adjustments to the control through the User Interface. The DIP switch settings change the items that are available to be viewed and / or adjusted in the User Interface.

If a DIP switch is changed while the control is powered up, the control responds to the change in setting by returning the display to the VIEW menu.

With the exception of **Adv / Installer**, **Rotate / OFF** and **Fixed Last / OFF** DIP switches, the DIP switch settings are the same as in Section A “Space Heating with Outdoor Reset”.

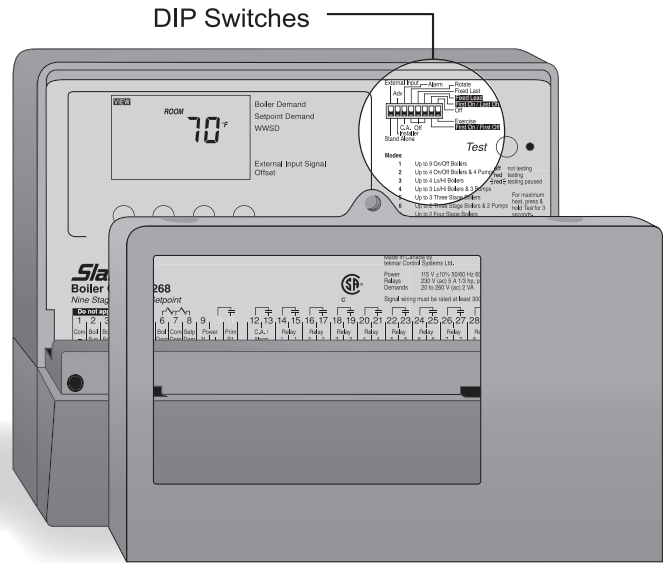

STEP 1: Set Advanced / Installer, Rotate / OFF and Fixed Last / OFF DIP switches as follows.

Advanced / Installer

The Adv / Installer DIP switch selects the access level of the control. In the Installer access level, a limited number of items may be viewed and / or adjusted. In the Advanced access level, all items may be viewed and / or adjusted.

Set to Adv

Rotate / Off

The Rotate / Off DIP switch selects whether or not the control is to provide Equal Run Time Rotation of the boiler stages. If the switch is set to Rotate, the stages will be rotated accordingly. If the switch is set to Off, the firing sequence is fixed starting with the lowest stage to the highest stage.

Set to Rotate



Fixed Last / Off

The Fixed Last / Off DIP switch selects whether or not the last boiler is to be included in the rotation sequence. If the DIP switch is set to Fixed Last, the last boiler is always the last to fire. This DIP switch is only active when the Rotate/Off DIP switch is set to Rotate.

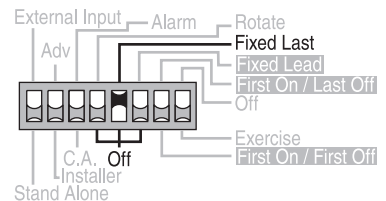
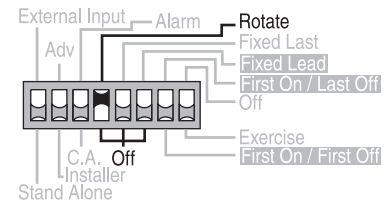
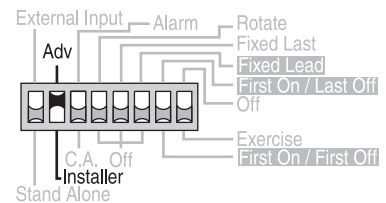
Must be set to fix last.

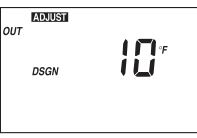
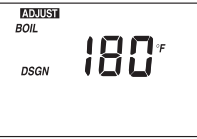
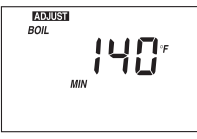

STEP 2: Program the following steps.

Display	Description	Default Setting	New Setting
	<p>X Outdoor Design - For Setpoint Operation MUST be adjusted.</p> <p>Move the Adv / Installer DIP switch to Installer. Press the Menu button until ADJUST is visible on the top line of the display. Press the Item button until OUT and DSGN appear. Use the up and down arrow buttons to change the setting to 45°F. Range Available: -60° to 45°F (-51° to 7°C)</p>	<p>10°F (12°C)</p>	<p>45°F (7°C)</p>
	<p>Boiler Design - The design supply water temperature used in the design of the system. Set at least 10°F above Boiler Minimum setting.</p> <p>Move the Adv / Installer DIP switch to the Adv position <i>temporarily</i>. Press the Menu button until ADJUST is visible on the top line of the display. Press the Item button until BOIL-DSGN appears. Use the up and down arrow buttons to change to the desired temperature. Move the Adv / Installer DIP switch back to the Installer position. Range Available: 70° to 220°F (21° to 104°C)</p>	<p>180°F (82°C)</p>	
	<p>Boiler Minimum - The Setpoint Control Temperature</p> <p>Move the Adv / Installer DIP switch to the Adv position <i>temporarily</i>. Press the Menu button until ADJUST is visible on the top line of the display. Press the Item button until BOIL MIN appears. Use the up and down arrow buttons to change to the DESIRED SETPOINT temperature - 140°F or more. Move the Adv / Installer DIP switch back to the Installer position. Range Available: OFF, 80° - 180°F (OFF, 27° - 82°C)</p>	<p>140°F (60°C)</p>	
	<p>Boiler Maximum - The maximum allowed boiler target temperature. Set at least 10°F above Boiler Design setting.</p> <p>Move the Adv / Installer DIP switch to the Adv position <i>temporarily</i>. Press the Menu button until ADJUST is visible on the top line of the display. Press the Item button until BOIL-MAX appears. Use the up and down arrow buttons to change to the desired temperature. Move the Adv / Installer DIP switch back to the Installer position. Range Available: 120° to 225°F or OFF (49° to 107°C or OFF)</p>	<p>200°F (93.5°C)</p>	

Please contact the Slant/Fin Technical Services Department if you need another way.

Please note that other ways may require additional relays for circulators.

Slant/Fin Technical Service 1-800-873-4346

When the WWSD (Warm Weather Shutdown) temperature is reached the operation or DHW is still active. Control of the DHW modules during a demand for DHW by-passes the SC-9 control.

Detailed information for ADV mode of ADV / Installer DIP switch



The SC-9 control has many features and some of these features are rarely used. These features are accessed and their settings changed when the **Adv / Installer** DIP switch is in the **Adv** position. As a reference, listed below is the list of all the features accessed with the DIP switch in **Adv** position. These are listed in sequential order as accessed in the SC-9 control.



STEP 1: Set **Adv / Installer** DIP switch in **Adv** position.

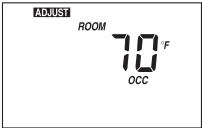
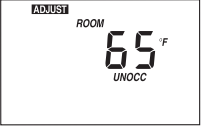
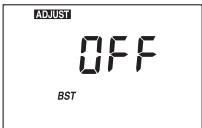
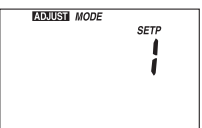

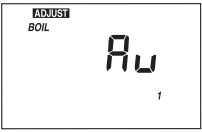
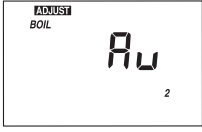
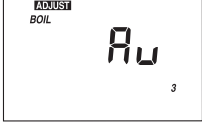
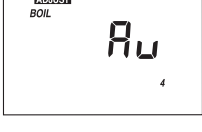
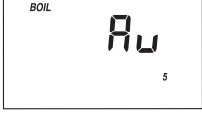
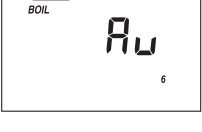
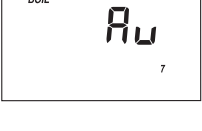
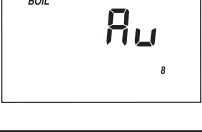
STEP 2: Press **Mode** button once.

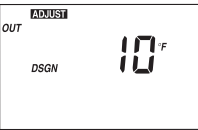
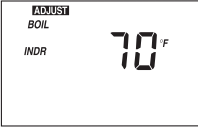
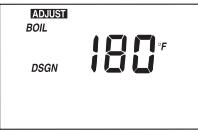
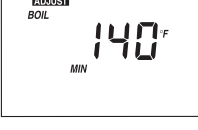
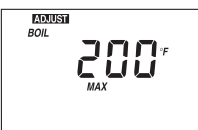
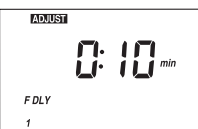

STEP 3: Press **Item** button repeatedly through the steps in sequence listed below.

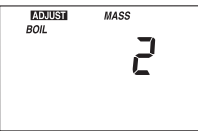
Display	Description	Default Setting	New Setting
	<p>Room Occupied - The desired room air temperature during the occupied period.</p> <p>This item is only available if the External Input/Stand Alone DIP switch is set to Stand Alone.</p> <p>Range Available: 35° to 100°F (2° to 38°C)</p>	<p>70°F (21°C)</p>	
	<p>Room Unoccupied - The desired room air temperature during the unoccupied period.</p> <p>This item is only available if the External Input/Stand Alone DIP switch is set to Stand Alone.</p> <p>Range Available: 35° to 100°F (2° to 38°C)</p>	<p>65°F (18.5°C)</p>	
	<p>Boost - The amount of morning boost.</p> <p>This item is only available if the External Input/Stand Alone DIP switch is set to Stand Alone.</p> <p>Range Available: OFF, 0:20 to 8:00 hr (5 minute increment)</p>	<p>OFF</p>	
	<p>Mode - Selects the staging mode of operation.</p> <p>Keep on 1</p>		

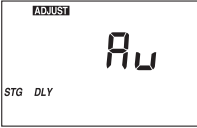
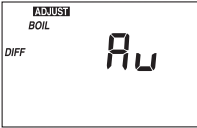
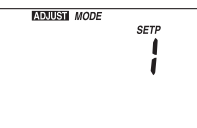
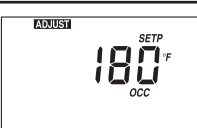
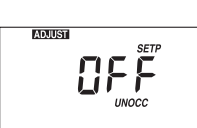
Display	Description	Default Setting	New Setting
	<p>Boiler 1 - Selects whether or not boiler 1 is operational</p> <p>This item is available in all modes. Range Available: Au (Auto), OFF</p>	<p>Au</p>	
	<p>Boiler 2 - Selects whether or not boiler 2 is operational</p> <p>This item is available in modes 1 to 7. Range Available: Au (Auto), OFF</p>	<p>Au</p>	
	<p>Boiler 3 - Selects whether or not boiler 3 is operational</p> <p>This item is available in modes 1 to 5. Range Available: Au (Auto), OFF</p>	<p>Au</p>	
	<p>Boiler 4 - Selects whether or not boiler 4 is operational</p> <p>This item is available in modes 1 to 3. Range Available: Au (Auto), OFF</p>	<p>Au</p>	
	<p>Boiler 5 - Selects whether or not boiler 5 is operational</p> <p>This item is available in mode 1. Range Available: Au (Auto), OFF</p>	<p>Au</p>	
	<p>Boiler 6 - Selects whether or not boiler 6 is operational</p> <p>This item is available in mode 1. Range Available: Au (Auto), OFF</p>	<p>Au</p>	
	<p>Boiler 7 - Selects whether or not boiler 7 is operational</p> <p>This item is available in mode 1. Range Available: Au (Auto), OFF</p>	<p>Au</p>	
	<p>Boiler 8- Selects whether or not boiler 8 is operational</p> <p>This item is available in mode 1. Range Available: Au (Auto), OFF</p>	<p>Au</p>	
	<p>Boiler 9- Selects whether or not boiler 9 is operational</p> <p>This item is available in mode 1. Range Available: Au (Auto), OFF</p>	<p>Au</p>	

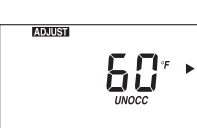
Display	Description	Default Setting	New Setting
 <p>ADJUST OUT DSGN 10^F</p>	<p>Outdoor Design - The design outdoor air temperature used in the heat loss calculations for the heating system.</p> <p>This item is only available if the External Input/Stand Alone DIP switch is set to Stand Alone. Range Available: -60° to 45°F (-51° to 7°C)</p>	<p>10°F (12°C)</p>	
 <p>ADJUST BOIL INDR 70^F</p>	<p>Boiler Indoor - The design indoor air temperature used in the heat loss calculation for the heating system.</p> <p>This item is only available if the External Input/Stand Alone DIP switch is set to Stand Alone. Range Available: 35° to 100°F (2° to 38°C)</p>	<p>70°F (21°C)</p>	
 <p>ADJUST BOIL DSGN 180^F</p>	<p>Boiler Design - The design supply water temperature used in the heat loss calculations for the heating system.</p> <p>This item is only available if the External Input/Stand Alone DIP switch is set to Stand Alone. Range Available: 70° to 220°F (21° to 104°C)</p>	<p>180°F (82°C)</p>	
 <p>ADJUST BOIL MIN 140^F</p>	<p>Boiler Minimum - The minimum allowed boiler target temperature</p> <p>Range Available: OFF, 80° to 180°F (OFF, 27° to 82°C)</p>	<p>140°F (60°C)</p>	
 <p>ADJUST BOIL MAX 200^F</p>	<p>Boiler Maximum - The maximum allowed boiler target temperature</p> <p>Range Available: 120° to 225°F, OFF (49° to 107°C, OFF)</p>	<p>200°F (93.5°C)</p>	
 <p>ADJUST F DLY 1 0:10^{min}</p>	<p>Fire Delay 1 - The time delay the control can expect between the time that the relay contact closes to fire the first stage of the boiler and the burner actually fires.</p> <p>Range Available: 0:00 to 3:00 minutes (1 sec increment)</p>	<p>0:10 min</p>	
 <p>ADJUST DLY 1:00^{min}</p>	<p>Combustion Air Damper Delay - The time allowed for the combustion air damper to open before the first stage is fired.</p> <p>This item is only available if the Alarm / C.A. DIP switch is set to C.A. Range Available: 0:00 to 3:00 minutes (1 sec increment)</p>	<p>1:00 min</p>	
 <p>ADJUST BOIL MASS 2</p>	<p>Boil Mass - The thermal mass characteristics of the boilers that are being used.</p> <p>Range Available: 1 (Lo), 2 (Med), 3 (Hi)</p>	<p>2</p>	

Display	Description	Default Setting	New Setting
	<p>Stage Delay - The minimum time delay between the operation of stages.</p> <p>Range Available: Au (Auto), 0:30 to 19:55 min (5 second increment)</p>	<p>Au</p>	
	<p>Boiler Differential - The temperature differential that the control is to use when it is operating the boiler(s)</p> <p>Range Available: Au (Auto), 2° to 42°F (Au, 1° to 23°C)</p>	<p>Au</p>	
	<p>Mode - Please keep this setting on 1.</p> <p>Failure to do so may cause the system pump to go off.</p> <p>Range Available: 1, 2 or 3</p>	<p>1</p>	
	<p>Setpoint Occupied - The minimum supply temperature when a setpoint demand is present during the Occupied period.</p> <p>In this mode the control will not energize the system circulator if you have voltage (between 24 and 230 volts AC) applied across terminals 7 and 8 on the control. These are the Com Dem (common demand) and Setp (setpoint demand) terminals. DO NOT apply voltage across these terminals. Please note we suggest you handle setpoint applications as explained in sections B and D in this manual. Leave control set at its default setting.</p> <p>This item is only available if the External Input / Stand Alone DIP switch is set to Stand Alone.</p> <p>Range Available: OFF, 60° to 220°F (OFF, 16 to 104°C)</p>	<p>180°F (82°C)</p>	
	<p>Setpoint Unoccupied - Selects whether or not a setpoint demand will be responded to during the UnOccupied period.</p> <p>In this mode the control will not energize the system circulator if you have voltage (between 24 and 230 volts AC) applied across terminals 7 and 8 on the control. These are the Com Dem (common demand) and Setp (setpoint demand) terminals. DO NOT apply voltage across these terminals. Please note we suggest you handle setpoint applications as explained in sections B and D in this manual. Leave control set at its default setting.</p> <p>This item is only available if the External Input / Stand Alone DIP switch is set to Stand Alone.</p> <p>Range Available: 35° to 100°F, OFF (2° to 38°C, OFF)</p>	<p>OFF</p>	
	<p>WWSD Occupied - The system's warm weather shut down temperature during the Occupied period.</p> <p>This item is only available if the External Input / Stand Alone DIP switch is set to Stand Alone.</p> <p>Range Available: 35° to 100°F, OFF (2° to 38°C, OFF)</p>	<p>70°F (21°C)</p>	
	<p>WWSD Unoccupied - The system's warm weather shut down temperature during the UnOccupied period.</p> <p>This item is only available if the External Input / Stand Alone DIP switch is set to Stand Alone.</p> <p>Range Available: 35° to 100°F, OFF (2° to 38°C, OFF)</p>	<p>60°F (15.5°C)</p>	

Display	Description	Default Setting	New Setting
	<p>Primary Pump Purge - The maximum length of time that the primary pump will continue to operate after the boiler demand has been removed.</p> <p>Range Available: OFF, 0:10 to 19:55 min (5 sec increment)</p>	<p>0:20 min</p>	
	<p>Units- The units of measure that all of the temperatures are to be displayed in by the control.</p> <p>Range Available: °F, °C</p>	<p>°F</p>	

NOTE: When you press the **ITEM** button again you will go to the beginning of the sequence

VIEW THE PERFORMANCE

FUNCTION	DESCRIPTION	STEPS
OUTDOOR	Current outdoor air temperature as measured by the outdoor sensor.	Press the Menu button until VIEW is visible on the top line of the display. Press the Item button until OUT appears. Read the numeric display.
BOILER SUPPLY	Current boiler supply water temperature as measured by the boiler supply sensor.	Press the Menu button until VIEW is visible on the top line of the display. Press the Item button until BOIL SUP appears. Read the numeric display.
BOILER TARGET	Boiler target temperature is the temperature the control is trying to maintain at the boiler supply sensor.	Move the Adv/ Installer DIP switch to the Adv position <i>temporarily</i> . Press the Menu button until VIEW is visible on the top line of the display. Press the Item button until BOIL TARG appears. Read the numeric display. Move the Adv/ Installer DIP switch back to the Installer position.
BOILER RETURN	Current boiler return water temperature as measured by the boiler return sensor.	Move the Adv/ Installer DIP switch to the Adv position <i>temporarily</i> . Press the Menu button until VIEW is visible on the top line of the display. Press the Item button until BOIL RET appears. Read the numeric display. Move the Adv/ Installer DIP switch back to the Installer position. <i>A boiler return sensor must be installed to view this item.</i>
DELTA T	Current difference in temperature between the boiler supply sensor and the boiler return sensor temperatures.	Move the Adv/Installer DIP switch to the Adv position <i>temporarily</i> . Press the Menu button until VIEW is visible on the top line of the display. Press the Item button until ΔT appears. Read the numeric display. Move the Adv/Installer DIP switch back to the Installer position. <i>A boiler return sensor must be installed to view this item</i>
BOILER 1 HOUR	The total running time of module 1 since this item was last cleared.	Move the Adv/Installer DIP switch to the Adv position <i>temporarily</i> . Press the Menu button until VIEW is visible. Press the Item button until BOIL appears on the second line of the display, and 1 in the lower right section. Read the numeric display in hours. To clear this item back to 0, press the Up and Down buttons simultaneously while viewing this item. Move the Adv/Installer DIP switch back to the Installer position.
BOILER 2 HOURS	The total running time of module 1 since this item was last cleared.	Move the Adv/Installer DIP switch to the Adv position <i>temporarily</i> . Press the Menu button until VIEW is visible. Press the Item button until BOIL appears on the second line of the display, and 2 in the lower right section. Read the numeric display in hours. To clear this item back to 0, press the Up and Down buttons simultaneously while viewing this item. Move the Adv/Installer DIP switch back to the Installer position.
BOILER 3 HOURS	The total running time of module 1 since this item was last cleared.	Move the Adv/Installer DIP switch to the Adv position <i>temporarily</i> . Press the Menu button until VIEW is visible. Press the Item button until BOIL appears on the second line of the display, and 3 in the lower right section. Read the numeric display in hours. To clear this item back to 0, press the Up and Down buttons simultaneously while viewing this item. Move the Adv/Installer DIP switch back to the Installer position.
BOILER 4 HOURS	The total running time of module 1 since this item was last cleared.	Move the Adv/Installer DIP switch to the Adv position <i>temporarily</i> . Press the Menu button until VIEW is visible. Press the Item button until BOIL appears on the second line of the display, and 4 in the lower right section. Read the numeric display in hours. To clear this item back to 0, press the Up and Down buttons simultaneously while viewing this item. Move the Adv/Installer DIP switch back to the Installer position.

Follow the above procedure for all remaining boiler stages

USEFUL HINTS

Hint #1

Reloading Factory Defaults

To reload the factory defaults, power down the control for 10 seconds. Power up the control while simultaneously holding the **Menu** and **t** buttons. The control will now display the **E01** error message. To clear this error message, follow the procedure in the Error Message section below.



E01 

The control was reloaded to factory default settings. However, the control will stop operation until all of the items in the **ADJUST** menu of the control have been checked by the user or installer. After checking all items press **MENU**.

NOTE: The Installer / Adv DIP Switch must be set to Adv in order to clear the error.

Hint #2

Room Occupied Setting

Changing the **Room Occupied** setting will change the heating curve. If you want more heat you should increase this setting above 70°F (21°C). If you want less heat you can decrease the setting below 70°F (21°C).

TESTING THE CONTROL

The control has a built-in test routine that is used to test the main control functions. The control continually monitors the sensors and displays an error message whenever a fault is found. See the following pages for a list of the control's error messages and possible causes. When the **Test** button is pressed, the test light is turned on. The individual outputs and relays are tested in the following test sequence.

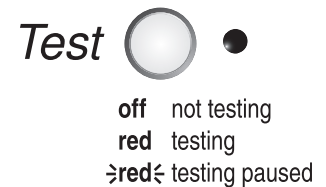

Test Sequence

Each step in the test sequence lasts 10 seconds.

During the test routine, if a demand from the system is present, the test sequence may be paused by pressing the **Test** button. If the **Test** button is not pressed again for 5 minutes while the test sequence is paused, the control exits the entire test routine. If the test sequence is paused, the **Test** button can be pressed again to advance to the next step. This can also be used to rapidly advance through the test sequence. To reach the desired step, repeatedly press and release the **Test** button until the appropriate device and segment in the display turn on.

STEP 1: The primary pump is turned on and remains on for the entire test routine.

STEP 2: If the **Alarm / C.A. DIP** switch is set to **Alarm**, the **Alarm** contact is turned on for 10 seconds and then shuts off. If the **Alarm / C.A. DIP** switch is set to **C.A.**, the Combustion Air Damper contact is turned on and remains on for the entire test routine.

STEP 3: For each boiler that is set to **Auto**, the following test sequence is used. If the mode indicates that a boiler pump is used, the boiler pump is turned on and remains on. Next, the first stage of the boiler is turned on and remains on. If a second stage is present, the second stage is turned on and remains on. If a third stage is present, the third stage is turned on and remains on. If a fourth stage is present, the fourth stage is turned on. After ten seconds, all stages and the boiler pump are turned off.

This step is repeated for each additional boiler that is set to **Auto**.

STEP 4: All contacts are turned off.

Error Messages



The control was unable to read a piece of information stored in its memory. Because of this, the control was required to reload the factory settings into all of the items in the ADJUST menu. The control will stop operation until all of the items in the ADJUST menu of the control have been checked by the user or installer.

Note: The Installer / Adv DIP Switch must be set to Adv in order to clear the error.



The control is no longer able to read the outdoor sensor due to a short circuit. In this case the control assumes an outdoor temperature of 32°F (0°C) and continues operation. Locate and repair the problem. To clear the error message from the control after the sensor has been repaired, press either the **Menu** or **Item** button.

This error message only occurs if the *External Input/Stand Alone DIP switch* is set to Stand Alone.

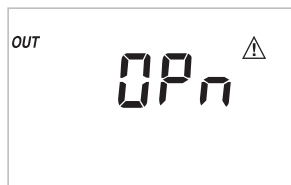

The control is no longer able to read the outdoor sensor due to an open circuit. In this case the control assumes an outdoor temperature of 32°F (0°C) and continues operation. Locate and repair the problem. To clear the error message from the control after the sensor has been repaired, press either the **Menu** or **Item** button.

This error message only occurs if the *External Input/Stand Alone DIP switch* is set to Stand Alone.



The control is no longer able to read the boiler supply sensor due to a short circuit. The control will not operate the boiler(s) until the sensor is repaired. Locate and repair the problem. To clear the error message from the control after the sensor has been repaired, press either the **Menu** or **Item** button.



The control is no longer able to read the boiler supply sensor due to an open circuit. The control will not operate the boiler(s) until the sensor is repaired. Locate and repair the problem. To clear the error message from the control after the sensor has been repaired, press either the **Menu** or **Item** button.

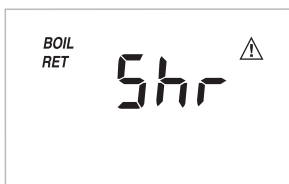

The control is no longer able to read the boiler return sensor due to a short circuit. The control will continue to operate normally. Locate and repair the problem. To clear the error message from the control after the sensor has been repaired, press either the **Menu** or **Item** button.



The control is no longer able to read the boiler return sensor due to an open circuit. The control will continue to operate normally. Locate and repair the problem. To clear the error message from the control after the sensor has been repaired, press either the **Menu** or **Item** button.

If the boiler return sensor was deliberately removed from the control, remove power from the control and repower the control to clear the error message.

Technical Data

Boiler Control SC-9 - Nine Stage Boiler & Setpoint

- Control — Microprocessor PID control; This is **not a safety (limit) control**.
- Packaged weight — 3.3 lb. (1500g), Enclosure A, blue modified PPO plastic
- Dimensions — 6-5/8" H x 7-9/16" W x 2-13/16" D (170 x 193 x 72 mm)
- Approvals — CSA C US, meets ICES & FCC regulations for EMI/RFI.
- Ambient conditions — Indoor use only, 30 to 120°F (0 to 50°C), <95% RH non-condensing.
- Power Supply — 115 V (ac) ± 10% 50/60 Hz 600 VA
- Relay capacity — 230 V (ac) ± 5 A 1/3 hp pilot duty 230 VA
- Demands — 20 to 260 V (ac) 2 VA
- Sensors included — NTC thermistor, 10 k Ω @ 77°F (25°C ± 0.2°C) β=3892
Outdoor Sensor 339070 and Universal Sensor 339071.

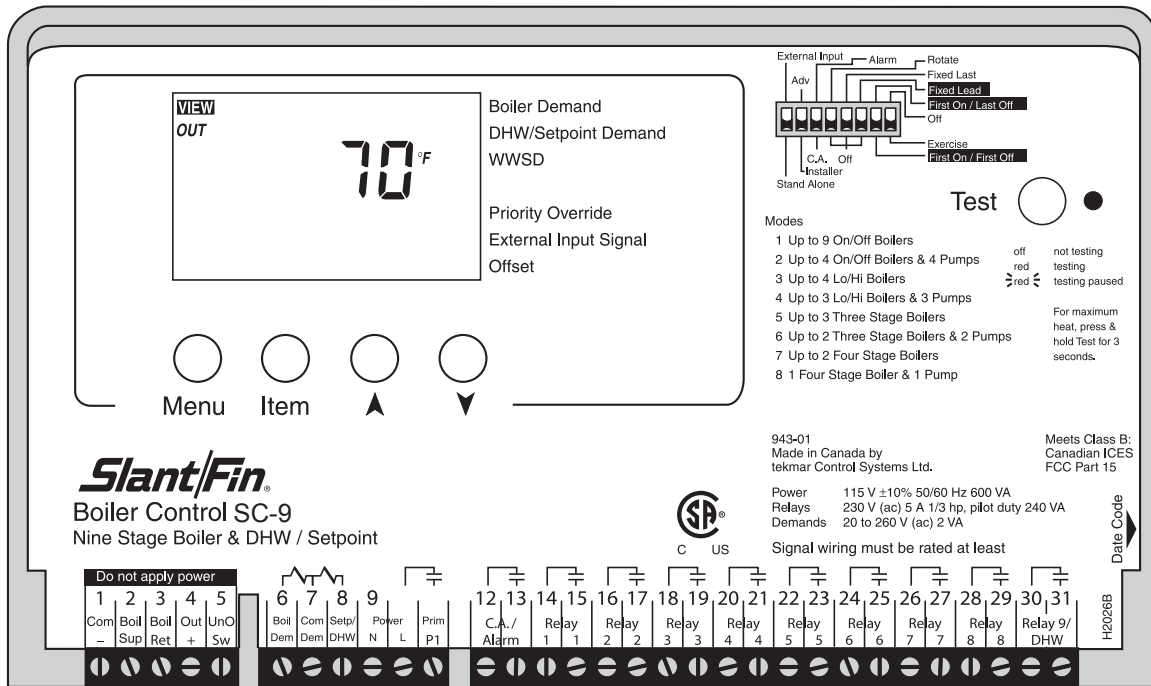

The installer must ensure that this control and its wiring are isolated and/or shielded from strong sources of electromagnetic noise. Conversely, this Class B digital apparatus complies with Part 15 of the FCC Rules and meets all requirements of the Canadian Interference-Causing Equipment Regulations. However, if this control does cause harmful interference to radio or television reception, which is determined by turning the control off and on, the user is encouraged to try to correct the interference by re-orientating or relocating the receiving antenna, relocating the receiver with respect to this control, and/or connecting the control to a different circuit from that to which the receiver is connected.

Caution: The nonmetallic enclosure does not provide grounding between conduit connections. Use grounding type bushings and jumper wires.

LISTING OF ALL FACTORY DEFAULT SETTINGS

FUNCTION	DEFAULT SETTING
ROOM OCC	70°F (21°C)
ROOM UN OCC	65°F (18°C)
BST	OFF
MODE	1
BOIL 1	Au
BOIL 2	Au
BOIL 3	Au
BOIL 4	Au
BOIL 5	Au
BOIL 6	Au
BOIL 7	Au
BOIL 8	Au
BOIL 9	Au
OUT DSGN	10°F (-12°C)
BOIL INDR	70°F (21°C)

FUNCTION	DEFAULT SETTING
BOIL MIN	140°F (60°C)
BOIL MAX	200°F (93°C)
F DLY 1	0:10 Min
DLY	1:00 Min
BOIL MASS	2
STG DLY	Au
BOIL DIFF	Au
MODE SETP	1
SETP OCC	180° (82°C)
SETP UNOCC	OFF
OCC WWSD	70° (21°C)
UN OCC WWSD	60° (16°C)
PURGE	0:20 Min
°F or °C	°F

PDF format instructions

A pdf version of this document is available.
Request Pub. No. SC9-40 (pdf)
by e-mail to: marketing@slantfin.com

