

Slant/Fin®



GALAXY™

GAS-FIRED CAST IRON BOILERS FOR NATURAL AND L.P. PROPANE GASES STEAM BOILERS

INSTALLATION AND OPERATING INSTRUCTIONS

LOW PRESSURE STEAM—Models GXH-230 through GXH-300H
LOW PRESSURE STEAM—Models GXHA-100 through GXHA-200

CONTENTS	PAGE
Dimensions.....	2
Installation Requirements:	
Boiler Location.....	3
Boiler Foundation.....	3
Chimney Requirements.....	3
Minimum Clearance.....	3
Vent Piping.....	4
Gas Piping.....	4
Electrical Controls and Wiring.....	5
Boiler Room Air Supply and Ventilation.....	5
Draft Hood Installation.....	5
Piping at Boiler—Steam Boilers.....	6
Steam Controls Assembly and Installation	6
Piping a Steam Boiler	6,7
Vent Damper.....	8,9
Operating Instructions:	
Filling and Venting Steam Systems.....	9-10
Initial Start, Safety and Lighting Instructions... ..	10-11
Burner Adjustment, Checking Gas Input.....	11
Controls, Safety Check.....	12
Low Water Cut-off Check-Out	12
Pressure Control Check-Out	12
Blowing Off a Steam Boiler.....	13
Care and Maintenance.....	14
Safety Check for Control System.....	14
Water Treatment.....	14
Sequence of Operations.....	15
Wiring Diagrams.....	16-17
Troubleshooting Guide.....	18
Replacement Parts.....	19
Appendix A	19

IMPORTANT

READ ALL OF THE FOLLOWING WARNINGS AND STATEMENTS BEFORE READING THE INSTALLATION INSTRUCTIONS

WARNING
SEE "WARNING" ON PAGE 3 FOR LIQUEFIED PETROLEUM (L.P.) PROPANE GAS-FIRED BOILERS

The installation must conform to the requirements of the authority having jurisdiction or, in the absence of such requirements, to the National Fuel Gas Code, ANSI Z223.1-latest edition. The installation must also conform to the additional requirements in this Slant/Fin Instruction Book.

In addition, where required by the authority having jurisdiction, the installation must conform to American Society of Mechanical Engineers Safety Code for Controls and Safety Devices for Automatically Fired Boilers, No. CSD-1.

This manual must be left with owner and should be hung on or adjacent to the boiler for reference.

WARNING

This boiler, gas piping and accessories must be installed, connected, serviced and repaired by a trained, experienced service technician, familiar with all precautions required for gas-fired equipment and licensed or otherwise qualified, in compliance with the authority having jurisdiction.

Heating Contractor <hr/> Address <hr/> Phone Number <hr/>	Boiler Model Number <hr/> Boiler Serial Number <hr/> Installation Date <hr/>
---	--

BOILER DIMENSIONS

GXH Series

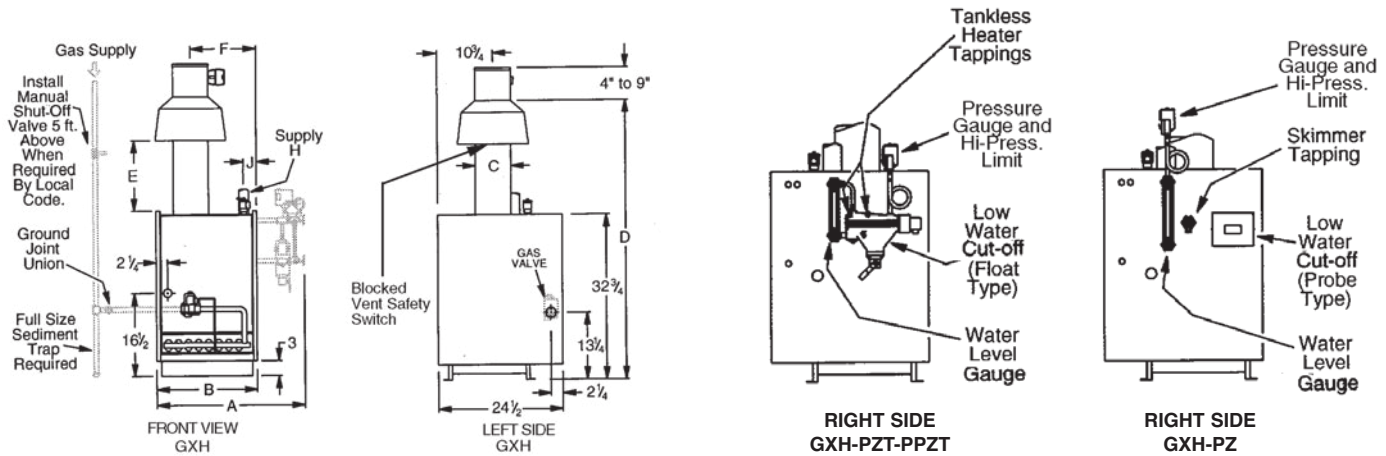

GXHA Series

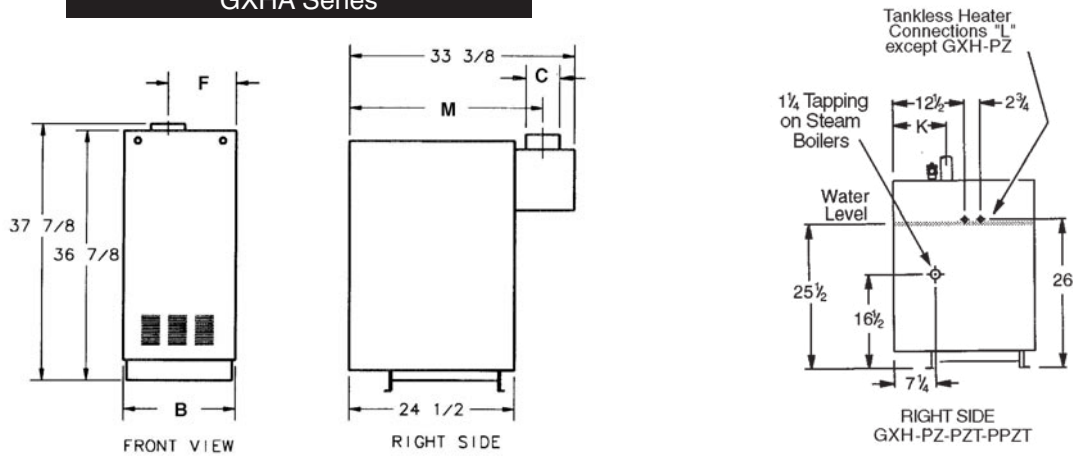

GXH AND GXHA SERIES STEAM BOILERS - DIMENSIONS IN INCHES

	GXHA-100	GXHA-120	GXHA-160	GXHA-200	GXH-230	GXH-250	GXH-275	GXH-300H
A	-	-	-	-	29 3/4	32 1/2	32 1/2	32 1/2
B	16 1/2	16 1/2	20	23 1/2	23 3/4	26	26	26
C	5	6	6	7	7	7	7	9
D	-	-	-	-	55 1/2	55 1/2	55 1/2	59 1/2
E	-	-	-	-	14	14	14	15
F	10	10	11 1/2	13 1/2	13	14 1/4	14 1/4	14 1/4
G	-	-	-	-	1 1/2	1 1/2	1 1/2	1 1/2
H	-	-	-	-	2 1/2	2 1/2	2 1/2	2 1/2
J	-	-	-	-	3 1/2	3 1/2	3 1/2	3 1/2
K	-	-	-	-	9 1/4	9 1/4	9 1/4	9 1/4
M	28 3/8	28 3/8	28 3/8	28 3/8	-	-	-	-

ORIFICE SIZES indicated for Sea Level are factory installed in boiler unless otherwise specified by the local authority.

See VII, page 11 for burner input adjustment.

GAS VALVE CONNECTION Size is 1/2" f.p.t. for all sizes.

COMBUSTIBLE FLOOR KIT increases all height dimensions by 1".

RAISED SLAB - When mounting boiler on a raised slab, the slab must extend at least 2" beyond the boiler cabinet on all sides.

CHIMNEY HEIGHT: 15 ft. minimum from draft hood skirt to top of chimney. **CHIMNEY INSIDE DIAMETER** must be same as Dimension "C" or larger. Larger diameter and/or height may be required if two or more boilers or a boiler and another appliance are vented to a single chimney.

BOILER MODEL	GAS TYPE	Orifice Size for Sea Level	ORIFICE SIZES AT HIGH ALTITUDES INCLUDES 4% INPUT REDUCTION FOR EACH 1000 FEET								
			ELEVATION- FEET								
			2,000	3,000	4,000	5,000	6,000	7,000	8,000	9,000	10,000
GXH-230 through 275	Natural	44	45	45	45	46	47	47	48	48	49
	Propane	54	54	55	55	55	55	55	56	56	56
GXH-300H	Natural Gas*	43	44	44	44	45	45	46	47	47	48
GXHA	Natural	45	46	47	47	47	48	48	49	49	50
	Propane	55	55	55	55	56	56	56	56	56	57

*For L.P. Propane gas, consult factory.

INSTALLATION REQUIREMENTS

The installation must conform to the requirements of the authority having jurisdiction or, in the absence of such requirements, to the National Fuel Gas Code, ANSI Z223.1-latest edition.

This installation must also conform to the additional requirements in this Slant/Fin instruction book. Installation and service to be performed by a qualified installer, service agency or the gas supplier.

NATURAL GAS-FIRED BOILER LOCATION—

Provide a level, solid foundation for the boiler. Location should be as near the chimney as possible so that the flue pipe from boiler to chimney is short and direct.

Automatic gas ignition system components shall be installed so these components will not be subjected to dripping water during installation or service.

WARNING

SPECIAL ATTENTION FOR LIQUEFIED PETROLEUM (L.P.) PROPANE GAS-FIRED BOILER INSTALLATIONS

LPG appliances (boilers) shall be installed in accordance with applicable provisions of NFPA 58 (Liquefied Petroleum Gas Code) latest edition for installations in US and CAN/CGA B149.1 latest edition for installations in Canada.

Liquefied Petroleum (LP) propane gas is heavier than air therefore Propane gas accumulate at floor level. If you suspect a leak, do not attempt to operate boiler. A spark or flame from the appliance (boiler) or other sources may ignite the accumulated propane gas causing an explosion or fire. It is recommended that inspections for gas leaks be performed periodically by licensed professional and that leak detection devices be installed as a further safety measure.

BOILER FOUNDATION

- A. Provide a solid, level foundation, capable of supporting the weight of the boiler filled with water, and extending at least 2" past the jacket on all sides. See dimensions of boilers, page 2.
- B. For installation on non-combustible floors only.*
- C. If boiler is to be located over buried conduit containing electric wires or telephone cables, consult local codes or the National Board of Fire Underwriters for specific requirements.

* The Combustible Floor Kit part number printed on the boiler rating plate is the only one to be used when installing on combustible floors. The boiler must NOT be installed on carpeting. DO NOT place boilers above floor area containing radiant tubing.

CHIMNEY REQUIREMENTS—

- A. Galaxy boilers may be vented into a masonry vitreous tile-lined chimney or UL LISTED Type "B" Venting system NOT EXPOSED to the OUTDOORS below the roof line. Venting and sizing of venting system must be in accordance with National Fuel Gas Code ANSI Z223.1, NFPA 54, -latest edition which will be referred to as the National Fuel Gas Code. Local codes apply. If a masonry chimney is exposed to the outdoors on one or more sides below the roof line (exterior chimney), ONE of the following options apply:
 1. Chimney must be re-lined with a UL LISTED metallic liner. When this is done, the chimney will be considered NOT exposed to the outdoors and the requirements of the National Fuel Gas Code for NON-exposed chimneys and/or local codes will apply.
 2. If an exposed tile-lined chimney is to be used WITHOUT a UL LISTED metallic liner, the boiler must first meet the requirements of the following tables and paragraphs of the National Fuel Gas Code:
- B. If an existing boiler is removed from a common venting system, the common venting system may be too large for proper venting of the remaining appliances connected to the common vent. Follow the test procedure shown in Appendix "A" on page 19 of this manual to insure proper operation of venting system and appliances.
- C. Inspect for proper and tight construction. Any restrictions or obstructions must be removed. An existing chimney may require cleaning.
- D. Chimney or vent must extend at least 3 feet above its passage through a roof and at least 2 feet above any ridge within 10 feet of the chimney.

MINIMUM CLEARANCES FROM COMBUSTIBLE CONSTRUCTION —

- A. Minimum boiler clearances shall be as follows:

GXH SERIES		GXHA SERIES	
MODELS GXH-230 TO GXH-300H, MINIMUM CLEARANCE FOR COMBUSTIBLE CONSTRUCTION. MINIMUM ALCOVE CLEARANCE.		MODELS GXHA-100, GXHA-120, GXHA-160 & GXHA-200 MINIMUM CLEARANCE FOR COMBUSTIBLE CONSTRUCTION. CLOSET AND ALCOVE CLEARANCE.	
Front	Alcove	Front	6"
Rear		Rear	6"
Left Side		Left Side	6"
Right Side	18"	Right Side	18"
Top	36"	Top	18"
Flue Connector	6"	Flue Connector	6"
Type 'B' Vent	1"	Type 'B' Vent	1"

- B. Provide accessibility clearance of 24" on sides requiring servicing and 18" on sides used for passage.
 - C. All minimum clearances shown above must be met. This may result in increased values of some minimum clearances in order to maintain the minimum clearances of others.
 - D. Clearance from steam and hot water pipes shall be 1". **
- ** At points where hot water or steam pipes emerge from a floor, wall or ceiling, the clearance at the opening through the finished floor boards or wall or ceiling boards may be not less than 1/2". Each such opening shall be covered with a plate of noncombustible material.

SAFETY—

KEEP THE BOILER AREA CLEAR AND FREE FROM COMBUSTIBLE MATERIALS, GASOLINE AND OTHER FLAMMABLE VAPORS AND LIQUIDS.

VENT PIPING—

- A. Vent piping installation must be in accordance with ANSI Z223.1-latest edition, National Fuel Gas Code, Part 7, Venting of Equipment. Other local codes may also apply and must be followed.
- B. Boiler vent pipe must be the full diameter of the boiler draft hood outlet. See dimensions, page 2. If a vent damper is added, its diameter must be equal to the hood outlet and must be located past the hood outlet. See installation instructions furnished with vent damper and in the section "Vent Damper Installation" of this instruction book.
- C. If more than one appliance vents into a common breeching, the area of the breeching must be equal to the area of the largest vent plus 50% of the area of the additional vent areas. Vent connectors serving appliances vented by natural draft shall not be connected into any portion of mechanical draft systems operating under positive pressure. Horizontal breeching or vent pipe should be as high as possible, consistent with codes, so that vertical vents from appliances will have a high rise above draft diverter openings. All horizontal runs must slope upwards not less than 1/4 inch per foot of run. Horizontal portions of the venting system must be supported to prevent sagging by securing each joint with metal screws and by providing hangers spaced no greater than 5 feet apart.
- D. Vent or breeching into chimney should not be inserted past the inside wall of the chimney liner.
- E. All venting means should be inspected frequently. See Care and Maintenance and separate User's Information Manual.

GAS PIPING—

- A. Local installation codes apply. The pipe joint compound used on threads must be resistant to the action of liquefied petroleum gases.
- B. The gas supply line to the boiler should be run directly from the meter for natural gas or from the fuel tank for L.P. propane gas. See page 2 for location of union and manual main shut-off valve that may be specified locally. Selecting pipe size for natural gas:
 1. Measure or estimate the length of piping from the meter to the installation site.
 2. Consult gas supplier for heating value of gas (BTU/cu. ft.).
 3. Divide boiler rated input by heating value to find gas flow in piping (cu. ft. per hour).
 4. Use table below to select proper pipe size.
 Example: Boiler model GXH-300H is to be installed. Distance from gas meter to the boiler is 50 ft. Heating value of natural gas is 1020 BTU/cu. ft. Select proper pipe size.

$$\text{Gas flow} = \frac{300,000 \text{ BTU/hour}}{1020 \text{ BTU/cu. ft.}} = 294 \text{ cu. ft. per hour}$$

At 50 ft. length of pipe, match required capacity from table below (choose higher capacity, in this case is 440 cu. ft. per hour). Required pipe size is 1-1/4". Improper gas pipe sizing will result in pilot flame outages, insufficient heat and other installation difficulties. For more information and also if other appliances are to be attached to the piping system, see Appendix C of National Fuel Gas Code ANSI Z223.1-latest edition.

- C. The boiler and its gas connection must be leak tested before placing the boiler in operation. Use liquid soap solution for all gas leak testing. DO NOT use open flame. This boiler and its individual shut-off valve must be disconnected from the gas supply piping system during any pressure testing of that system at test pressures in excess of 1/2 PSIG. This boiler must be isolated from the gas supply piping system by closing its individual manual shut-off valve during any pressure testing of the gas supply piping system at test pressures equal to or less than 1/2 PSIG.
- D. All gas piping used should be inspected thoroughly for cleanliness before makeup. A sediment trap must be provided, as illustrated on page 2.
- E. The minimum and maximum gas supply pressure (at the inlet of gas valve) are shown on the boiler rating plate for the type of gas used. Gas supply pressure should never be less than minimum or more than maximum pressure when the boiler or any other appliance is turned on or off.

Length of Pipe in Feet	Gas Flow In Piping — cu. ft. per hr.				
	Iron Pipe Size (IPS) — inches				
	1/2	3/4	1	1-1/4	1-1/2
10	132	278	520	1050	1600
20	92	190	350	730	1100
30	73	152	285	590	890
40	63	130	245	500	760
50	56	115	215	440	670
60	50	105	195	400	610
70	46	96	180	370	560
80	43	90	170	350	530
90	40	84	160	320	490
100	38	79	150	305	460

ELECTRICAL CONTROLS AND WIRING—

- A. The electrical power to the boiler must be on a separately fused and live circuit.
- B. If an external electrical source is utilized, the boiler, when installed, must be electrically grounded in accordance with the requirements of the authority having jurisdiction or, in absence of such requirements, with the National Electrical Code, ANSI/NFPA No. 70-latest edition.
- C. Basic control wiring diagrams are given on pages 16-17. Other control systems may be factory supplied, see User's Information Manual and Instructions packed with control system supplied.
- D. After placing the boiler in operation, the safety shut-off device must be tested. See page 12 safety check.

BOILER ROOM AIR SUPPLY AND VENTILATION

An ample supply of air is required to obtain combustion and ventilation. Room temperature over 100°F may cause nuisance tripping of the Blocked Vent Safety Switch.

ALL AIR MUST COME FROM OUTSIDE, directly through wall openings to the boiler or through unsealed openings around windows, doors, etc. in the whole building. When buildings are insulated, caulked and weather-stripped, now or later on, direct opening to outside may be required and should be provided. If the boiler is not on an outside wall, air may be ducted to it from outside wall openings.

The National Fuel Gas Code, ANSI Z223.1-latest edition specifies openings for air under various conditions. Local codes may specify minimum opening sizes and locations. The following recommendation applies to buildings of energy-saving construction, fully caulked and weather-stripped:

Provide one GRILLED opening near the floor and one near the ceiling on an outside wall near the boiler (or duct from such openings to the boiler), EACH opening to be a minimum of one square inch per 2000 Btuh input to ALL APPLIANCES in the area. For a total appliance input of 200,000 Btuh, each opening will be 100 square inches. A grilled opening 10" x 10" has 100 square inches of area. If fly screen must be used over openings, double the area and inspect and clean the screen frequently.

Openings must NEVER be reduced or closed. If doors or windows are used for air supply, they must be locked open. Protect against closure of openings by snow and debris. Inspect frequently.

NO MECHANICAL DRAFT EXHAUST OR SUPPLY FANS ARE TO BE USED IN OR NEAR THE BOILER AREA.

The flow of combustion and ventilating air to the boiler must NOT be obstructed.

DRAFT HOOD—

The draft hood supplied is part of the listed boiler assembly. DO NOT alter the hood. See dimensions, page 2.

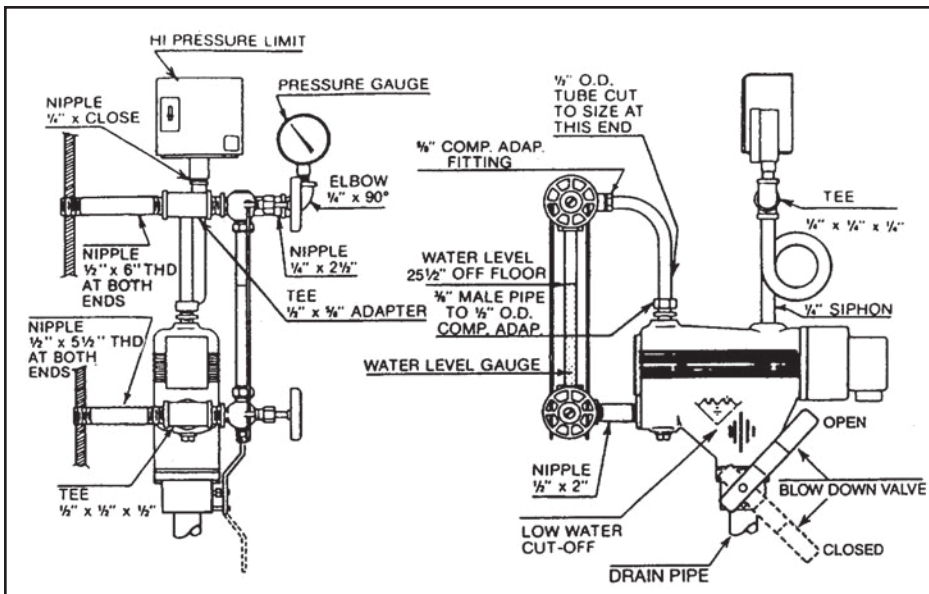

Steam Control Assembly

SPECIAL FLUSHING INSTRUCTIONS
 Installation of new boiler may break loose a heavy accumulation of sediment and scale from old piping and radiators. It is extremely important to blow down your McDonnell Cut-off 67 more frequently the first week.
 First week — 3 times
 Thereafter — at least once a week
 * Exception: McDonnell Cut-off 42A must be blown down daily.
 See "CARE AND MAINTENANCE" for instructions.

Attach the hood to the boiler flue outlet. Connect flue pipe full size of hood outlet. If a vent damper is added, it must be installed on the outlet side of the hood. See Vent Piping, on page 4.

INSTALLATION INSTRUCTIONS FOR GXH OR GXHA LOW PRESSURE STEAM BOILERS EQUIPPED WITH TANKLESS OR PROVISION FOR TANKLESS AND McDONNELL & MILLER TYPE 67 LOW WATER CUT-OFF. STEAM CONTROLS ASSEMBLY AND INSTALLATION INSTRUCTIONS

Steam kit components for Galaxy packaged models are packed as follows:

- A. 1. Low water cut-off control
 - 2. Fittings
 - 3. L.W.C.O. instruction sheet
- B. 1. Pressure gauge
 - 2. High pressure limit control
 - 3. Water level gauge
 - 4. Fittings
 - 5. Instruction sheet and assembly drawing
 - 6. Steam safety valve and 3/4" street coupling
 - 7. Drain cock

Assemble above components exactly as shown in steam controls assembly. Two 1/2" tappings are on right side of boiler for this assembly. Two holes are pre-punched in jackets. For convenience, start assembling in the following steps:

1. Install 1/2" x 5-1/2" brass nipple onto tee of L.W.C.O.
2. Mount 1/2" x 5-1/2" brass nipple into lower boiler tapping by rotating low water cut-off.
3. Assemble 90° brass tubing to tee adapter and L.W.C.O.
4. Install 1/2" x 6" brass nipple and 1/2" x 5/8" adapter tee in upper boiler tapping.
5. Install syphon, high pressure limit and pressure gauge with 1/4" brass fittings.
6. Install water level gauge (without glass) and its fittings.
7. Install water level glass, and mark the glass 25-1/2" from the bottom of the steel boiler base for the water level. (The steel boiler base should not be confused with a combustible floor kit when making the 25-1/2" measurement.)
8. Drain cock will be installed in return tee at the lower right side of casting.
9. Safety valve and 3/4" street coupling should be installed in 3/4" tapping on top of boiler.

PIPING A LOW PRESSURE STEAM BOILER

Boilers must be piped with good engineering practice and must conform to the requirements of ANSI/ASME Boiler and Pressure Vessel Code section IV and to the authority having jurisdiction.

NOTES:

1. Slant/Fin makes no recommendation, nor does Slant/Fin imply that One Pipe Parallel and Counterflow Gravity Condensate Return systems shown on page 7 are the preferred systems. These systems are merely two examples of many possible systems. Determination of the proper system is based upon the application and is therefore beyond the scope of this instruction.
2. The 18" minimum height shown in figures 1-3, is the minimum height between the top of the jacket of the boiler and the 2-1/2" x 12" header centerline in the supply piping from the boiler. It must NOT be confused with the minimum height between the water level and the lowest return bend of the steam supply main. This height is "H" as shown in figures 2 and 3.

The minimum height of "H" must be at least equal to the sum of the pressure drop of the system plus three times the friction loss of the wet return, but not less than 18" for a system with a 1/8" psi steam pressure drop and not less than 28" for a system with a 1/2" psi steam pressure drop.

3. Modern steam boilers are smaller in water content than the boilers that they replace, therefore a mechanical return system (pump, receiver, etc.) must be employed if conditions exist such that uniform condensate return flow to the boiler cannot be maintained.

Pocketing of condensate and the inability to maintain the correct minimum height between the steam supply main and the water level in the boiler are but a few of the many conditions that indicate the use of a mechanical return system. Any use of a receiver and pump must be coordinated with the makeup water and controlled by the boiler water level control on the boiler. This description is typical of a boiler feed pump as opposed to a condensate pump that pumps condensate regardless of the water level in the boiler.

4. In any steam system one of the requirements is the removal of air from the system. A mechanical return system in most cases has an air vent on the receiver. A gravity return system has no receiver, so provisions for air removal must be made on the piping itself. A one pipe system has the air vents on the radiation, the heat exchanger and near the end of the steam supply main (see figures 2 and 3).

Main air vents should be located fifteen inches from the drip and if possible eight inches above the pipe so that water hammer does not damage the vent and render the vent inoperable.

For more information on air vents, check with any manufacturer of steam accessories (steam traps, boiler feed pumps, air vents, etc.).

5. Process water applications involving steam boilers requires the use of heat exchangers. Any process application that constantly uses fresh water into a steam boiler can and will cause scaling with deposits forming in the boiler and surrounding piping. This will damage the boiler.
6. If valves are used on the supply side of the boiler, the valve port opening must be the same size as the surrounding pipe. (Full flow type valves.)
7. Piping should provide a means of cleaning and flushing the heating system of the sediment for safe, efficient operation.

RECOMMENDED PIPING FOR A ONE PIPE PARALLEL FLOW LOW PRESSURE STEAM HEATING SYSTEM WITH A WET OR DRY GRAVITY (See Note No. 3) CONDENSATE RETURN AND A HARTFORD† LOOP.

See Note No. 1 on page 6.

FIGURE 1

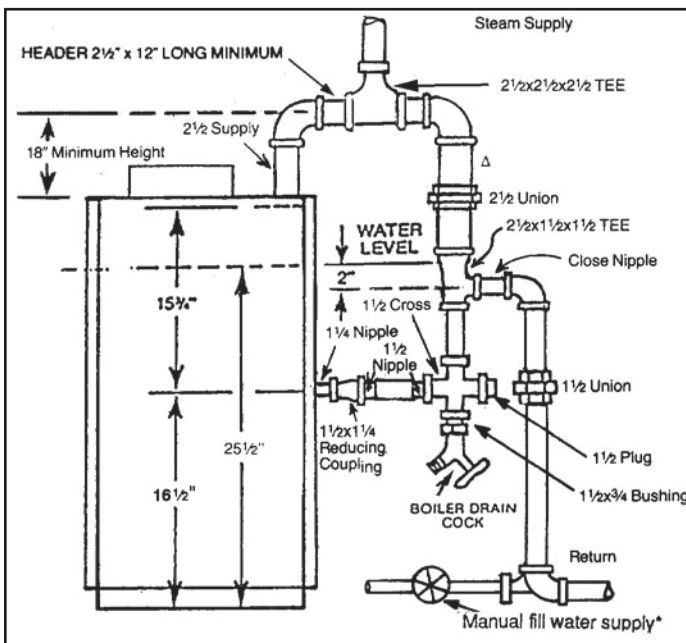

- † A Hartford Loop is recommended for low pressure steam systems with gravity condensate returns. Pipe sizes shown above for Hartford Loop are recommended by Slant/Fin. However, certain local codes may require larger pipe sizes. Consult with local authorities.
- Δ The equalizer should be full size from the steam supply to the operating water level.
- * Hot water fill is preferable. For auto feedings, see manufacturer's technical instructions.

FIGURE 2

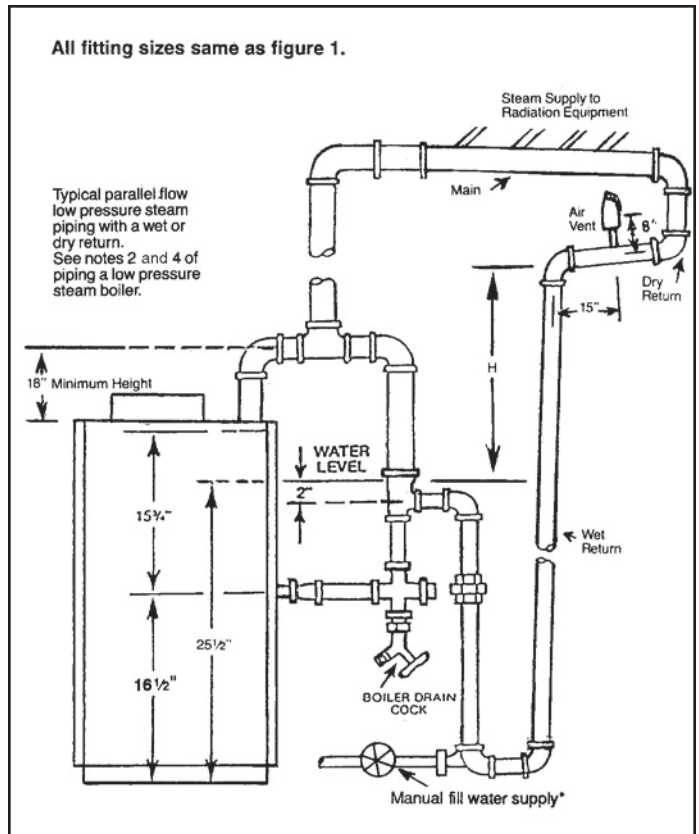

* Hot water fill is preferable, but not required. For auto feeding, see manufacturer's technical instructions.

FIGURE 3

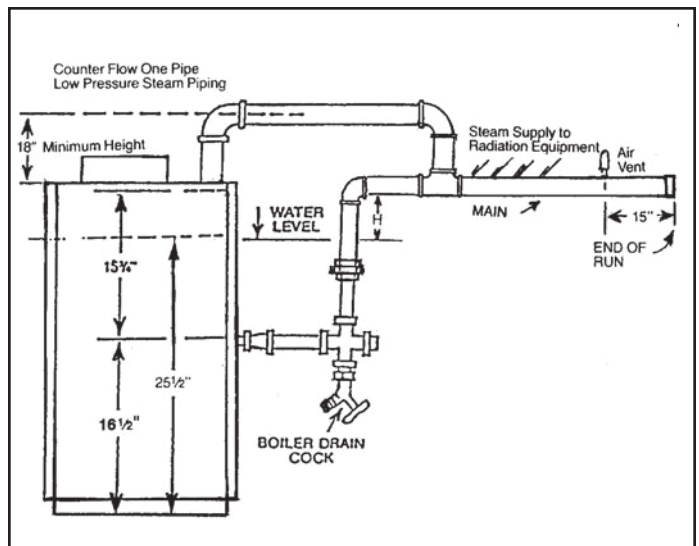

Counter flow piping is sized one pipe size larger than a parallel flow piping. This allows steam to travel in one direction while the condensate travels in the other direction. This along with a steeper pitch is a must for safe, efficient operation.

VENT DAMPER INSTALLATION

The vent damper referred to in the following instructions is the Slant/Fin Corporation vent damper.

This device is design certified by CSA for use ONLY on specific Slant/Fin Corp. gas boiler models. These boilers must also be equipped with a plate which states that the boiler must or may be used with a Slant/Fin Corp. automatic vent damper device and indicates the proper vent damper model number.

A. INSTALLATION INSTRUCTIONS BEFORE YOU START TO INSTALL

1. Read this installation manual, the "DANGER" plate attached to the top of the boiler, the "WARNING" on the wiring diagrams, vent damper carton and operator cover.
2. Perform pre-installation inspection as required by ANSI specification Z21.66.
3. Select a proper, convenient location (see figures 4 and 5).
4. Carefully unpack the unit. DO NOT FORCE IT OPEN OR CLOSED. Forcing the damper may damage the gear train and void the warranty.

WARNING—DANGER

Once you have begun vent damper installation procedure, DO NOT restore electric power and gas supply until installation and inspection have been completed (in order to prevent the main burners from operating). DO NOT operate the boiler until the vent damper harness "RECEPTACLE B" is plugged into "MALE PLUG" (as described in the installation instructions), and the vent damper installation and checkout procedures have been completed. Failure to observe this warning may create a hazardous condition that could cause an explosion or carbon monoxide poisoning.

- B. 1. This device must be installed after the appliance draft hood (between the draft hood outlet and the connector to the outdoor chimney or vent) as close to the draft hood as practicable, and without modification of the draft hood or the damper. (See figures 4 and 5.)
2. The inlet size of the vent damper must be the same nominal trade size as the outlet of the draft hood.
3. This device must be located in a venting system or section of a venting system so that it serves only the single appliance for which it is installed. (See fig. 9.)
4. Clearances of not less than 6 inches (152mm) must be maintained from combustible materials, with provisions for access for service.
5. GXHA steam boilers are equipped with integral draft diverter consists of front section (factory assembled to the boiler) and the rear section (shipped with the boiler). The rear section must be assembled to the boiler using three sheet metal screws (see figure 7).

Vent damper may be installed vertical or horizontal (see figure 8a & 8b)

C. NOW, PROCEED AS FOLLOWS:

1. Remove the front cover of the boiler exposing the wiring compartment. With all electrical power to boiler off, locate "MALE PLUG" (for GXH-300HEZ boiler, locate "Receptacle A") (see wiring diagram attached to boiler); a copy of this may also be found in this manual. To find the correct wiring diagram in this manual, match the number found in the lower right hand corner of the boiler wiring diagram with the identical number on one of the diagrams in this manual.)

For GXH-00HEZ, cut the RED wire connected between numbers 3 and 4 of "RECEPTACLE A" (the only wire connected to this receptacle) and then disconnect

FIGURE 4

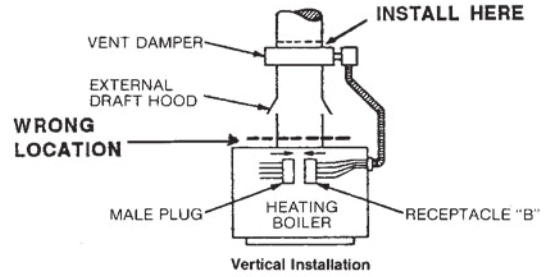
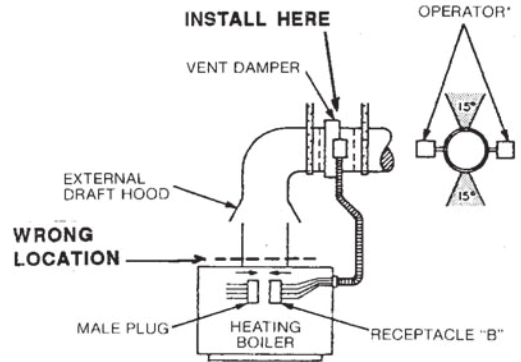
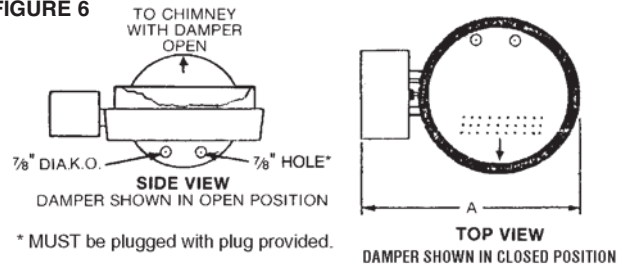

FIGURE 5



INSTALL OPERATOR IN ANY POSITION AS SHOWN ABOVE. DO NOT INSTALL THE OPERATOR ABOVE THE VENT PIPE (TO AVOID EXCESSIVE HEAT) OR BELOW THE VENT PIPE (TO AVOID POSSIBLE CONDENSATE DAMAGE).

FIGURE 6



* MUST be plugged with plug provided.

TABLE

Vent Size	5"	6"	7"	8"	9"
A	10 ⁵ / ₁₆ "	11 ⁵ / ₁₆ "	12 ⁵ / ₁₆ "	13 ⁵ / ₁₆ "	14 ⁵ / ₁₆ "

FIGURE 7

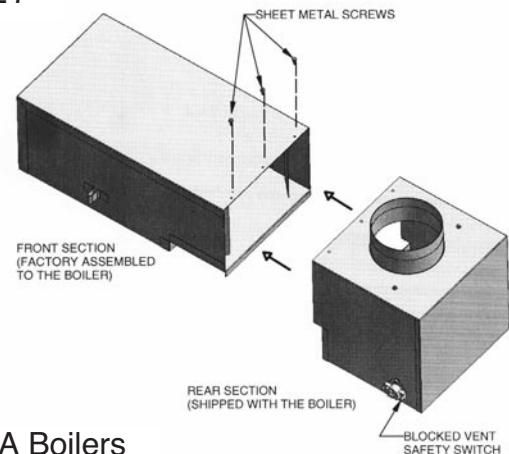

GXHA Boilers

FIGURE 8a & 8b

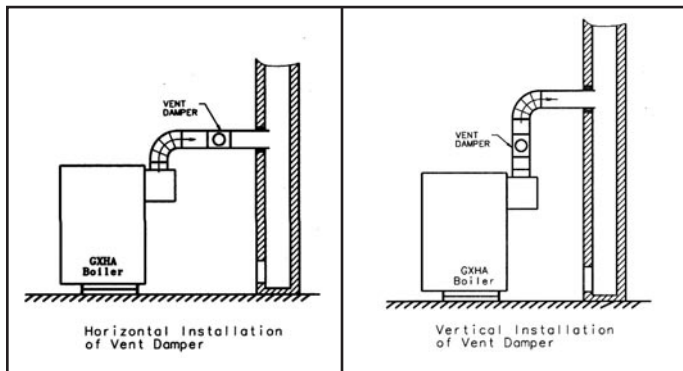
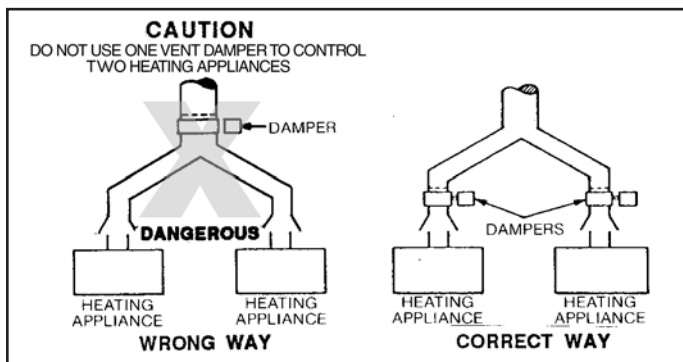

FIGURE 9



"RECEPTACLE A" from "MALE PLUG". Remove "RECEPTACLE A" from job site and discard.

2. Separate the vent pipe directly on top of the draft hood or diverter and place damper in position as shown in figures 4 - 9. The vent damper must be installed so that the damper position indicator is in a visible location after installation for position indicator description. The arrow imprint on the damper should point in direction of vent gas flow (towards chimney). Re-assemble the vent piping. Be sure the vent damper is well seated and fastened with 3 sheet metal screws. Screws should be no longer than 1/2 inch.
3. Be sure that undersized vent pipe does not block movement of damper vane.
4. Boilers that may have vent damper are factory wired with plug and "RECEPTACLE A". To install the vent damper all that is required is removal of the "RECEPTACLE A" and connection of the vent damper harness to the boiler plug. (Remove "RECEPTACLE A" from job site and discard.) Boilers that must have a vent damper are factory wired with plug only.
 - a) Attach the flexible metallic conduit vent damper harness to the right hand side of the jacket by passing the free end of the harness through the 7/8" diameter hole in the top of the jacket, and using the BX connector at the free end of the metallic conduit, fasten to jacket.
 - b) Connect "RECEPTACLE B" (free end of vent damper harness) into "MALE PLUG" (see correct wiring diagram for both continuous and intermittent pilots).
5. All Slant/Fin Corp. Galaxy steam boilers equipped with intermittent pilot ignition and continuous (standing) pilot systems are factory wired except for the wires to the low water cut-off and pressure cut-off. Wire these controls with wire provided with boiler (see boiler wiring diagram on boiler). Then follow previous instructions shown in #4 above.

- GXHA boilers only: Two provided red wires must be connected to "blocked vent safety switch located on the rear section of the draft diverter (see figure 7).
6. Restore electrical power and turn on gas supply.

D. AFTER INSTALLATION:

1. Operate system through two complete cycles to check for opening and closing in proper sequence, and proper burner operation. DAMPER MUST BE IN OPEN POSITION WHEN BOILER MAIN BURNERS ARE OPERATING.
2. Perform installation checks as required by ANSI specification Z21.66.
3. Replace the front cover of the boiler.
4. Check the troubleshooting section if problems arise with the installation.

E. THERMOSTAT HEAT ANTICIPATOR ADJUSTMENTS

If the 24V room thermostat that controls this boiler has an adjustable heat anticipator and has previously been adjusted without a vent damper, then see publication VD-40 for correct electrical requirement adder for the vent damper used. If room thermostat has not been adjusted, connect entire system to thermostat and run the system while measuring the current drawn through the thermostat wires. Set the heat anticipator at the value of current measured. For more information, see Slant/Fin vent damper installation manual, pub. VD-40, and the manufacturer's vent damper booklet shipped with the vent damper.

OPERATING INSTRUCTIONS, BASIC

Before firing boiler, make these checks:

1. Relief valve is installed. Installation of the relief valve shall be consistent with the ANSI/ASME Boiler Pressure Vessel Code. Valve opening is NOT closed or reduced in size.
2. Draft hood is installed and vented to chimney.
3. All wiring is completed, following applicable wiring diagrams.
4. If a vent damper is added, damper is in full open position. See instructions furnished with vent damper.
5. Using soap solution, check for gas leaks in all gas piping from meter to boiler pilot and manifold. DO NOT use open flame.

I. CLEANING AND FILLING A NEW STEAM BOILER

Before using steam boiler:

- A. Check boiler to be certain it is ready for firing. DO NOT FIRE into an empty boiler.
- B. Be prepared to heat raw water to at least 180° F as soon as it is introduced into the boiler. This procedure will remove dissolved, corrosive gases.
- C. Provide drain line, with valve, from boiler. Use a bottom tapping. Line and drain must be suitable for handling caustic solution.

II. CLEAN STEAM BOILER SYSTEM

- A. Fill the boiler to water line indicated on the boiler.
- B. Follow start-up procedure for boiler and operate the boiler with steam in the entire system for 2 or 3 days to bring oil and dirt from the system to the boiler. While system is in operation, maintain the proper water level in the boiler by slowly adding water to the boiler.
- C. Shut down burner, cool down boiler and drain system.
- D. Procedure to dissolve oil and grease in boiler:
 1. Fill boiler to proper water line.
 2. Prepare a boil-out solution of caustic soda.

NOTE: Use CAUTION in handling chemicals. Caustic soda is harmful to skin, eyes and clothing.

 (a) Pour solution into the boiler through a top tapping. Replace plug.

3. Start the burner; boil the water for at least 5 hours; shut off the burner.
- E. With CAUTION, drain the boiler solution to a safe location. DO NOT LEAVE SOLUTION SITTING IN SYSTEM OVER 2 HOURS.
- F. Wash the water side of the boiler thoroughly using a high pressure water stream. Fill and drain the boiler several times.

III. TREATING WATER FOR CORROSION CONTROL

(This is not scale control.)

- A. Prepare a boil-out solution of caustic soda.
Proportions: 1 lb. per 50 gallons of boiler water.
- B. Stir chemical in water until dissolved and pour into boiler through a top tapping. Replace plug.

IV. FILLING AND VENTING THE STEAM BOILER

- A. Refill the boiler to the indicated water line.
- B. Bring water to boiling temperature, promptly.
- C. The boiler is now ready to be put into service or on standby.

V. INITIAL START

Safe lighting and other performance criteria were met when testing various gas manifold and control assemblies used on the Galaxy Series boilers under the ANSI Z21.13b-latest edition.

SAFETY INFORMATION

FOR YOUR SAFETY READ BEFORE OPERATING

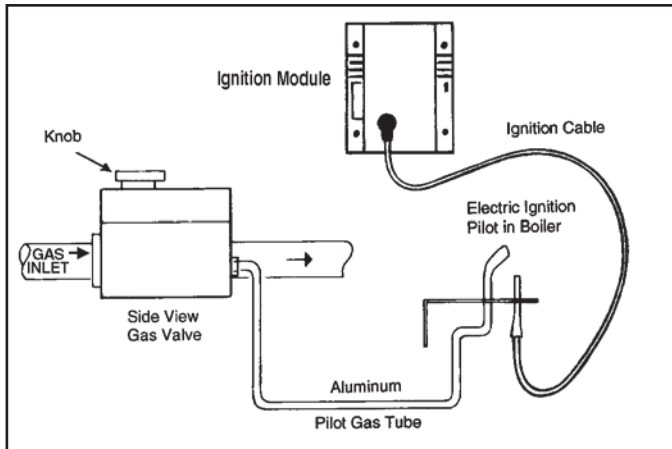

WARNING: If you do not follow these instructions exactly, a fire or explosion may result causing property damage, personal injury or loss of life.



- A. This appliance is equipped with an ignition device which automatically lights the pilot. DO NOT try to light the pilot by hand.
- B. BEFORE OPERATING smell all around the appliance area for gas. Be sure to smell next to the floor because some gas is heavier than air and will settle on the floor.
WHAT TO DO IF YOU SMELL GAS
 - DO NOT try to light any appliance.
 - DO NOT touch any electric switch; DO NOT use any phone in your building.
 - Immediately call your gas supplier from a neighbor's phone. Follow the gas supplier's instructions.
 - If you cannot reach your gas supplier, call the fire department.

- C. Use only your hand to push in or turn the gas control knob. NEVER use tools. If the knob will not push in or turn by hand, DON'T try to repair it, call a qualified service technician. Force or attempted repair may result in a fire or explosion.
- D. DO NOT use this appliance if any part has been underwater. Immediately call a qualified service technician to inspect the appliance and to replace any part of the control system and any gas control which has been underwater.

Operating Instructions

1. **STOP!** Read the safety information on this page.
2. Set the thermostat to lowest setting.
3. Turn off all electric power to the appliance.
4. This appliance is equipped with an ignition device which automatically lights the pilot. DO NOT try to light the pilot by hand.
5. Remove control access panel. (Galaxy models only.)
6. Turn gas control knob clockwise  to "OFF". DO NOT force.
7. Wait five (5) minutes (longer for propane) to clear out any gas, then smell for gas, including near the floor. If you then smell gas, **STOP!** Follow "B" in the safety information on this page. If you don't smell gas, go to next step.
8. Turn gas control knob counterclockwise  to "ON".
9. Replace control access panel. (Galaxy models only.)
10. Turn on all electric power to the appliance.
11. Set thermostat to desired setting.
12. If the appliance will not operate, follow the instructions "To Turn Off Gas To Appliance" and call your service technician or gas supplier.

To Turn Off Gas To Appliance

1. Set the thermostat to lowest setting.
2. Turn off all electric power to the appliance if service is to be performed.
3. Remove control access panel. (Galaxy models only.)
4. Turn gas control knob clockwise  to "OFF". DO NOT force.
5. Replace control access panel. (Galaxy models only.)

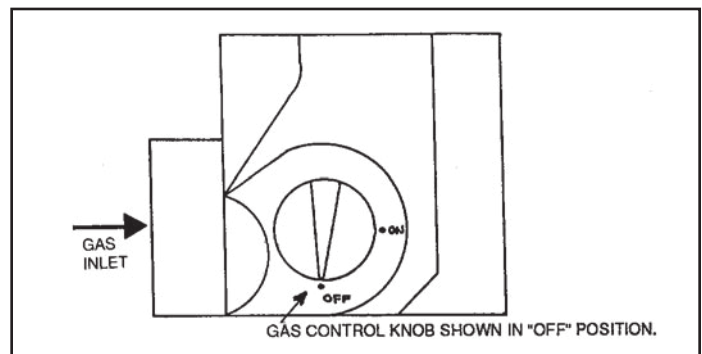

BURNER ADJUSTMENT

A. Adjust gas input rate:

1. Consult gas supplier for heating value of gas (Btu/cu.ft.).
2. Set thermostat high enough so that boiler will remain on while checking rate.
3. Measure manifold pressure at 1/8" tapping. Correct manifold pressure for gas used is printed on boiler rating plate. NOTE: Gas pressure may be adjusted by turning pressure regulator screw on combination gas valve (Turn clockwise to increase pressure, counterclockwise to decrease pressure).
 - a. Input for PROPANE is approximately at rating shown on rating plate when manifold pressure is 9-1/2" water column.
 - b. Input for NATURAL GAS is approximately at rating when manifold pressure is 3-1/2" water column, but should be checked on the gas meter:

$$\text{Btuh Input} = \text{Btuh/cu. ft.} \times \text{cu. ft. metered in 3 minutes} \times 20$$

Example #1:

For 1000 Btu/cu. ft. gas, this becomes:

$$\text{Btuh Input} = \text{cu. ft. metered in 3 minutes} \times 1000 \text{ Btu/cu.ft.} \times 20$$

Example #2:

For 1050 Btu/cu. ft. gas, this becomes:

$$\text{Btuh Input} = \text{cu. ft. metered in 3 minutes} \times 1050 \text{ Btu/cu.ft.} \times 20$$

4. The higher* heating value of gas varies substantially for different localities. Consult with Slant/Fin's Technical Service Dept. for re-orificing procedures if any of the following apply:
 - a. Boiler (burner) is overfiring. **CAUTION!** National Fuel Gas Code (ANSI Z223.1-latest edition) does NOT permit firing at a higher input rate than the input rate indicated on the boiler rating plate in order to avoid hazardous conditions such as explosion or carbon monoxide poisoning.
 - b. Poor higher* heating value of gas is causing the actual input to be substantially lower than the rating plate indication.

* "Higher heating value" of gas is commonly known as "heating value"

GAS RATE TABLE

The gas metered in 3 minutes to obtain rated input for each boiler model, using 1000 Btu/cu. ft. gas is tabulated in gas rate table.

Boiler rated input in cu. ft./hr. of 1000 Btu/cu.ft. Natural Gas	Cubic Feet Gas Consumption 1000 Btu/cu. ft. gas, in 3 minutes, at rated output
100	5.00
120	6.00
125	6.25
150	7.50
160	8.00
175	8.75
200	10.00
225	11.25
250	12.50
275	13.75
300	15.00

B. Main Burner

1. Fire the boiler continuously for at least 15 minutes, to reach burner operating temperature.
2. Observe the flames, all burners. The base of all flame jets should be blue. The tips should be blue shading to orange. NOTE: Dust, disturbed by any movement, will cause bright orange flames. Wait for dust to settle.
3. For one burner, close the air shutter until some of its flame jet tips turn yellow-white, indicating insufficient primary air. Then open shutter until whitish tips disappear completely. Set all burner shutters to the same opening. Observe to make sure that no yellow-white tips appear over any portion of the flame. Small yellow tips at the pilot location are permitted.

NOTE: This adjustment method gives MINIMUM primary air setting for safe combustion. DO NOT attempt to make this adjustment unless burners are at operating temperature. Adjustment should be made with jackets in final operating position. Use of mirror may be helpful to observe flames. Note that burner ports are on top of main burner tube.

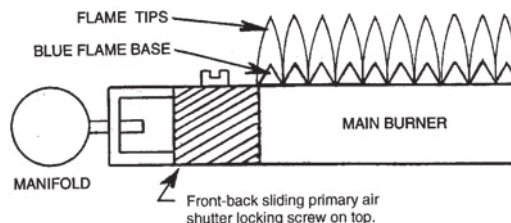

C. Main Burner Ignition Check-out and Pilot Adjustment

1. The pilot flame must not smother or snuff out when tested as follows:
 - a. Main burner ignition from cold start-repeat.
 - b. Continued operation of main burner.
 - c. Main burner ignition with appliance at maximum operating temperature after prolonged operation.

NOTE: Observe operation of the pilot burner with appliance doors in the final operating position. Use of a mirror may be helpful.
2. Safety Shutdown Check-out
 - a. For proper operation the pilot should engulf the thermocouple, powerpile generator or flame sensor as shown below.

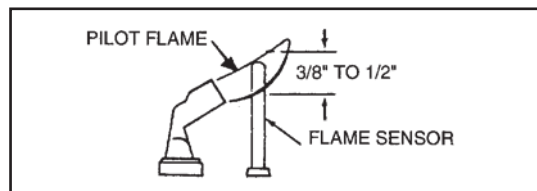

- b. To adjust pilot, turn pilot flow adjustment screw on valve clockwise or counterclockwise to give a steady flame enveloping 3/8" to 1/2" of the tip of the thermocouple, generator or flame sensor. Note that turning the pilot adjustment screw clockwise will decrease the pilot flame.
- c. Check safety shutdown of gas valve by following procedure outlined "CARE AND MAINTENANCE" section.

CONTROLS, SAFETY CHECK

Check all safety controls not previously mentioned. Also, follow directions in "CARE AND MAINTENANCE" section.

These boilers are equipped with both a draft hood blocked vent safety switch and a rollout safety switch. The blocked vent safety switch is located on the draft hood flue stack. This is a manual reset control used to prevent excessive spillage of flue gases from the draft hood. The rollout safety switch is a single use (one time) thermal fuse to prevent the boiler from operating if flue passages are blocked. If either of these devices shut down the burners, follow instructions in the section "To Turn Off Gas To Appliance" and call your service technician or gas supplier.

LOW WATER CUT-OFF CHECK-OUT

A. Electronic Probe Type Low Water Cut-off. If this boiler is factory equipped with an electronic probe type low water cut-off, operation of cut-off should be checked at least twice a year as follows.

1. While boiler is running, drain down boiler water slowly through boiler drain cock shown on page 7, just until light goes on. Boiler should shut down 90 seconds after light goes on.
2. Be sure that it is the low water cut-off and not the room thermostat, pressure cut-off, energy cut-off or other control that has shut off the burner.
3. Refill the boiler and repeat test.
4. Refill the boiler and reset controls for normal operation.

B. Float type low water cut-off. If this boiler is factory equipped with a McDonnell & Miller float type low water cut-off, the low water cut-off must be blown down (flushed), at least once a week.

1. **CAUTION:** When flushing float type low water cut-off control, hot water and steam will flow out the blow down valve. Blow down valve is illustrated on page 5.

SPECIAL FLUSHING INSTRUCTIONS
 Installation of new boiler may break loose a heavy accumulation of sediment and scale from old piping and radiators. It is extremely important to blow down your McDonnell cut-off more frequently the first week.
 First week — 3 times
 Thereafter — at least once a week

2. As boiler water circulates through the float chamber, dirt or other sediment may be deposited. This chamber is extra deep. But the only sure way to keep any accumulation from interfering with float action is to "blow down," or flush out, the control once a week.

Do it while boiler is in operation. First note water level in gauge glass. Open blow-off valve at bottom of control; water will pour out, flushing away sediment. Drain until water is clear—about a pail—then close valve. If level in gauge glass has dropped, add water to boiler to restore level.

Steam controls assembly

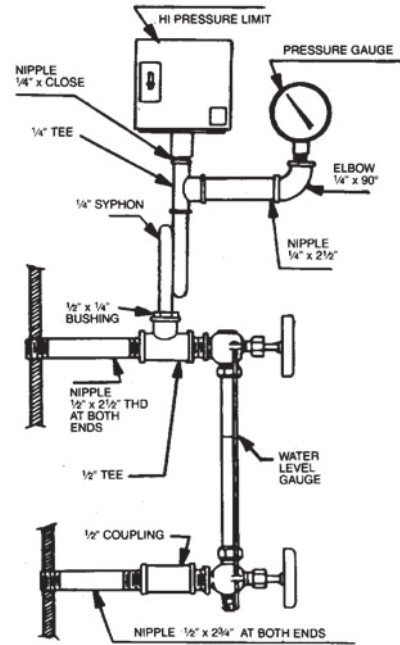

3. **NOTE:** Opening blow-off valve checks cut-off operation too. As float drops with falling water level, burner will stop. After valve is closed and normal operating conditions restored, burner will resume firing.
4. Be sure that it is the low water cut-off and not the room thermostat, pressure cut-off, energy cut-off or other control that has shut off the burner.

PRESSURE CONTROL CHECK-OUT

- A. Check burner to be certain it is ready for firing. **DO NOT FIRE** into an empty boiler.
- B. Set thermostat high enough for boiler to make steam. Set the pressure control down to its lowest setting. As the boiler starts to produce steam, the steam pressure will start to build. The burner will shut off when the steam pressure exceeds the pressure setting (plus differential if the control has this feature).
- C. Adjust the pressure control to a higher setting. The higher setting should be above the steam pressure in the boiler. This should turn the burner back on.
- D. Reset the pressure control as needed for the system. The pressure control should be checked out at least twice a year.

Steam Controls Installation Instructions

Steam kit components for Galaxy packaged models are packed as follows:

1. Low water cut-off control, electric, installed.
2. Pressure gauge.
3. High pressure limit control.
4. Water level gauge.
5. Fittings.
6. Instruction sheet and assembly drawing.
7. Steam safety valve and 3/4" street coupling.
8. Drain cock.

Assembly above components exactly as shown. Two 1/2" tapings are on right side of boiler for this assembly. Two holes are pre-punched in jackets.

Replacement of Steam Boilers

Anytime an older steam boiler is removed from the heating system and replaced with a new boiler, there are certain conditions that have to be examined on the heating system.

1. Steam systems have a tendency to develop scale inside the wet return lines and the boiler. The older the system the greater the accumulation of scale that can exist inside the piping. Therefore, it is necessary when replacing a steam boiler to check the piping for blockage or restrictions. Clean or replace the piping as required.
2. Replace all buried wet return lines.
3. All equipment (air vents, radiation equipment, etc.) in the steam heating system should be checked for proper operation. All piping should be checked for proper pitch.
4. It is good engineering practice to repack or tighten the packing nuts on all valves in the heating system.

BLOWING OFF A LOW PRESSURE STEAM BOILER

1. MODELS THAT HAVE NO TANKLESS HEATER OR NO PROVISION FOR HEATER

- A. Those models without tankless heaters or provision for tankless heaters have a skimmer giving the advantages of a surface blow pipe, that has been built into the casting to insure rapid skimming of oil and grease through a 3/4" N.P.T. tapping located on the right hand jacket side panel, 8-9/16" from the top and 13-1/4" from the front of the boiler (see Figure A).
- B. Turn off electrical power supply to boiler. Allow boiler to cool down and steam pressure to reduce to zero before removing skimmer tapping plug. Check for steam pressure by testing the pop safety valve. Keep your hands and all parts of your body away from the discharge end of the safety valve. Drain boiler down one to two inches below skimmer tapping. There will be water in the skimmer trough. The water might be hot. Remove skimmer plug slowly and carefully. Install 3/4" skimmer valve, elbow and length of pipe and place a bucket underneath the open end of the pipe. Cover bucket with a piece of cloth.
- C. Fill boiler slowly until water level is two inches from top of gauge glass. (This is the starting water level for skimming only.) Fire boiler to produce steam. If the system is

heavily laden with oil, it may be difficult to obtain much more than a pound or so of pressure. Set the pressure control at about 7 psi. The higher the steam pressure you can use, the better and faster the cleaning.

- D. As a steam develops, open the SKIMMER drain valve with caution to skim the oil and film from the top of the water. DO NOT open the boiler drain valve. Close the skimmer drain valve when the water level drops to about 5" from the top of the gauge glass. The water may stop before the level drops to 5" below the top of the glass. Refill boiler until water level is again two inches from the top of the gauge glass.
- E. Repeat (D) above until all film is skimmed off and the water settles to a desired normal movement. Add makeup fresh water to the boiler as described in (D) above during the blow-off operation to maintain the proper skimming water level in the vessel. Empty bucket frequently in order to see the difference in water cleanliness.
- F. When surging has stopped and water is clean, and no film can be seen floating in the bucket, shut off boiler, drain down to level of skimmer tapping, remove valve, plug skimmer tapping and refill the boiler to the normal operating water (25-1/2" from the bottom of the boiler—see Figure A below). Check the pop safety valve for proper operation.
- G. The entire process may have to be repeated over a period of a few days on extremely fouled systems.

2. MODELS WITH TANKLESS HEATER OR WITH TANK-LESS HEATER PLATES ONLY.

- A. Turn off electrical power supply to boiler. Allow boiler to cool down and allow pressure to reduce to zero before attempting removal of components. Check for steam pressure by testing safety valve. Keep your hands and body away from the discharge end of the valve. Remove pop safety valve and re-pipe boiler as shown in Figure B below, making sure to reinstall pop safety valve on tee to complete the blow off connection.
- B. Connect a length of pipe to the elbow and place a bucket underneath the open end of the pipe, cover bucket with a piece of cloth.

FIGURE A
Right side view of Galaxy models that are NOT equipped with or DO NOT have provisions for tankless heaters.

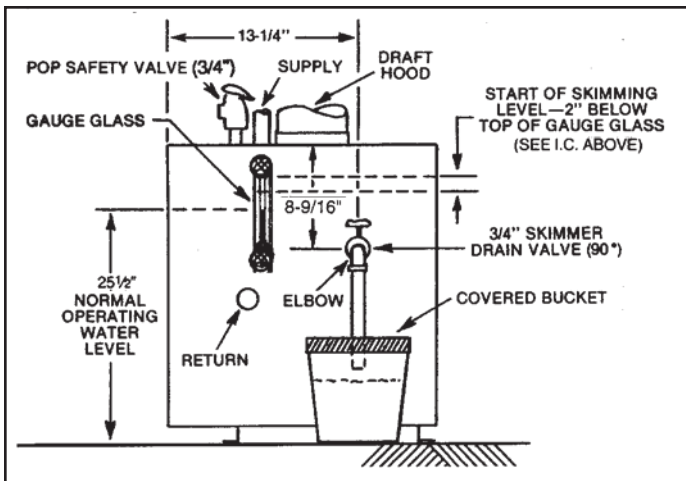
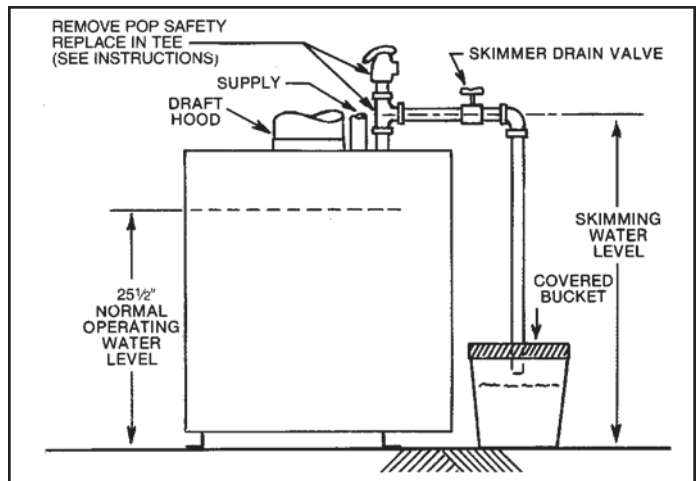

FIGURE B
Left side view of Galaxy models that are equipped with or have provisions for tankless heaters.



- C. Open the SKIMMER drain valve with caution. DO NOT open the boiler drain valve. Fill the boiler slowly until water begins to seep into the bucket from the skimmer drain blow-off connection. Fire the boiler. Allow water to heat up while water seeps into the bucket. Maintain that water level necessary just to be able to continue skimming. Continue until water is clean and no oil can be seen floating in the bucket. Empty bucket frequently in order to see if the water is clean.
- D. Repeat this process until all film is skimmed off, lower the water level to 25-1/2" from the bottom of the boiler (see Figure B). When all surging has stopped, turn off the boiler, remove skimmer valve and plug the tee. Check the pop safety valve for proper operation.
- E. The entire process may have to be repeated over a period of a few days on extremely fouled systems.

3. CLEANING PIPING SYSTEM

- A. To clean piping system, open all valves at the heating elements, after getting up a good head of steam, shut the boiler down and allow the condensate to return to the boiler. The condensate will carry the oil film with it. Again blow-off the boiler. On extremely fouled systems, it may require several visits over a period of a few days to clean the system.
- B. When steam only (no water) is released through the hand valve, the boiler will not surge or flood.

CARE AND MAINTENANCE

WARNING: THE FLOW OF COMBUSTION AND VENTILATING AIR TO THE BOILER SHOULD NOT BE OBSTRUCTED.

This section must be brought to the attention of the owner by the installer so that the owner can make the necessary arrangements with a qualified service agency for the periodic care and maintenance of this boiler. The installer must inform the owner that the gas supplier can recommend a number of qualified service agencies. The installer must also inform the owner that the lack of proper care and maintenance of this boiler and any fuel burning equipment may result in a hazardous condition.

1. GENERAL MAINTENANCE (Refer also to User's Information Manual)

These operations are recommended to be performed at regular intervals:

 - A. BOILER HEATING SURFACES: clean off all coatings found.
 - B. BOILER CONTROLS: check contacts, settings, correct functioning.
 - C. PIPING: check piping and accessories for leaks.
 - D. CHIMNEY and BREECHING: check for obstructions and leaks.
 - E. BOILER ROOM AIR SUPPLY: check air vents for continued POSITIVE supply of air as required. Air needs are greatest in cold weather. Air vents must be open and free of obstruction.
2. WATER LEVEL CHECK DURING HEATING SEASON:
 - A. Check water level regularly and add water slowly to system when needed. If much water is added, venting may be necessary.
 - B. Regular loss of water from water boiler system may indicate either a system leak, or a faulty air-control system, or a faulty automatic fill valve.
3. ANNUAL INSPECTION AND CLEANING:
 - A. It is important that this boiler be inspected by a competent serviceperson to help insure safe and reliable operation.
 - B. Check for gas leaks from valve and gas piping to burners and pilot. If leaks are found, repair or replace as required.
 - C. This inspection should include:
 1. Controls check. See SAFETY CHECK, IV. on page 16.
 2. Recheck of input gas rate to burners. See "Initial Start" paragraph in "Operating Instructions" section.

3. Re-adjusting for best flame characteristics of main flame and pilot(s). See "Initial Start" paragraph in "Operating Instructions" section and see "Burner Adjustment" section.
4. Burner and boiler flue passage cleanliness: BURNER AND FLUE CLEANING (see sketch). It is suggested that paper be placed on burners to collect any foreign material in cleaning flues.
5. Remove draft hood, jacket top and flue cover.
6. Use wire brush to clean flueways.
7. Replace flue cover and re-seal with furnace cement. Replace jacket top and draft hood and reconnect to smoke pipe, using screws. Remove and dispose of paper and accumulated material.
8. If burner surfaces are not clean, or if uneven flame indicates plugged burner ports, remove and clean burners.

NOTE—TO REMOVE BURNERS:

- a. Disconnect pilot at pilot mount, or disconnect pilot gas line at gas valve, before removing burners next to pilot.
- b. Lift rear of burner and remove burner from orifice.
- c. Clean and replace burners* and pilot. Adjust burners as described on page 11.

* To clean burners run a clean flue brush up the tube until all foreign matter is removed.

Boiler Cleaning

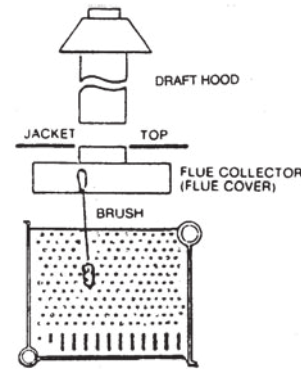

WARNING:

The ceramic combustion chamber in the burner box contains crystalline silica. Wear proper dust mask and gloves when servicing combustion chamber or burners. Crystalline Silica has been identified as a carcinogenic or possibly carcinogenic to humans.

4. SAFETY CHECK FOR CONTROL SYSTEM
 - A. Gas valve safety shutdown test:
 1. For boilers equipped with Honeywell S8600F or M or S8670E intermittent pilot system, with main burners firing, disconnect the ignition cable from the S8600F or M or S8670E IGNITOR BOX. The gas valve should shut off the main burners.

If the gas valve fails to shut down main burners when the test in 1 or 2 is performed, replace the gas valve.
 - B. Check for gas leaks from valve and gas piping to burners and pilot. If leaks are found, repair or replace as required.
5. Water Treatment:

A good water treatment program will not only extend the useful life of this boiler but it will also save much of the time and expense of repairs made necessary by preventable occurrences. A reputable water treatment company should be consulted to evaluate and determine the best overall treatment program for your boiler equipment.
6. KEEP THE BOILER AREA CLEAR AND FREE FROM COMBUSTIBLE MATERIALS, GASOLINE, AND OTHER FLAMMABLE VAPORS AND LIQUIDS.

SEQUENCE OF OPERATION FOR GALAXY STEAM BOILERS

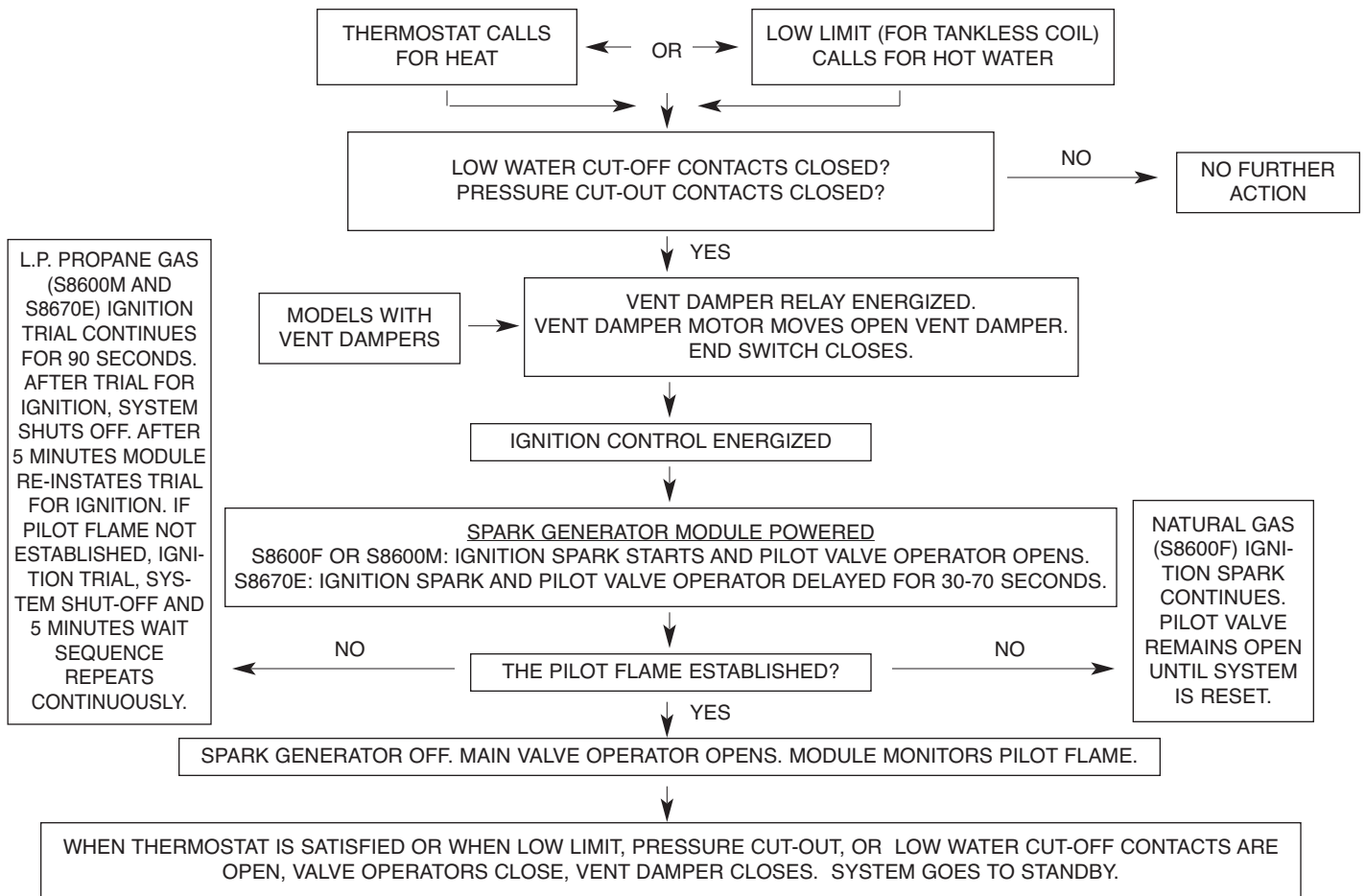

WIRING DIAGRAMS FOR STEAM BOILERS WITH VENT DAMPER

CAUTION: Label all wires prior to disconnection when servicing control.
Wiring errors can cause improper and dangerous operation. "Verify proper operation after servicing."

STEAM (PZ,PZT AND PPZT) BOILER WITH 24V HONEYWELL INTERMITTENT IGNITION, VENT DAMPER AND MM-67 L.W.C.O. (LO LIMIT IF W/ TANKLESS)

WARNING:

BLOCKED VENT SAFETY SWITCH MUST BE MOUNTED TO DRAFT HOOD BEFORE OPERATING THE BOILER (SEE INSTRUCTION MANUAL GALAXY GGS-41)
BEFORE INSTALLING VENT DAMPER, READ WARNING LABEL ON THIS BOILER AND VENT DAMPER. READ SLANT/FIN VENT DAMPER INSTALLATION INSTRUCTIONS.
FOR PROPANE USE S8600M OR S8670E, FOR NATURAL GAS S8600F, S8600M OR S8670E.

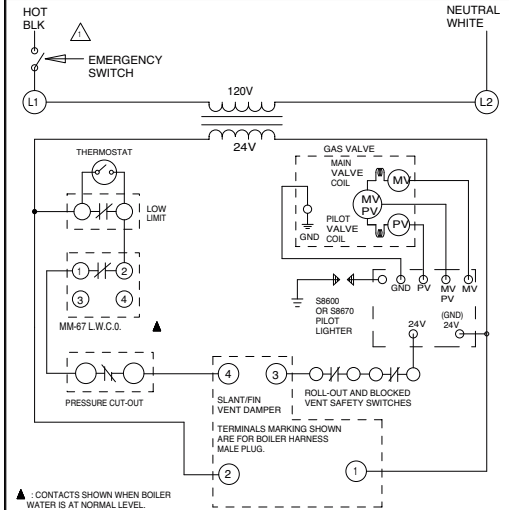
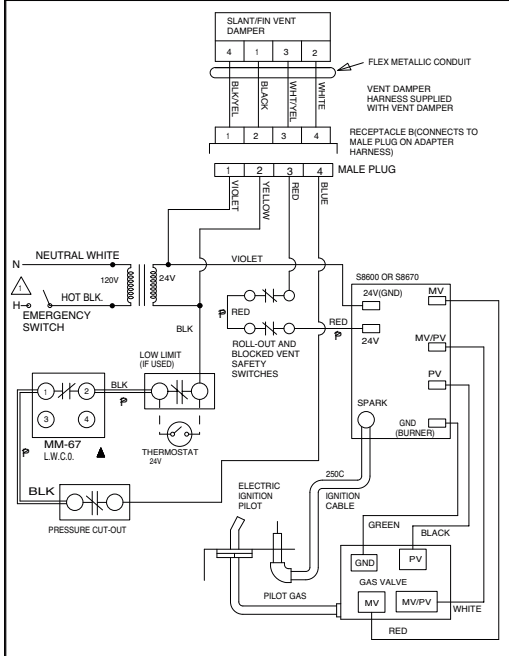

▲ : CONTACTS SHOWN WHEN BOILER WATER IS AT NORMAL LEVEL.

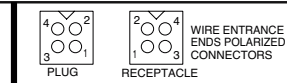
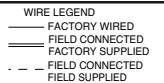

▲ PROVIDE DISCONNECT MEANS & OVERLOAD PROTECTION AS REQUIRED.
IF ANY OF THE ORIGINAL WIRE AS SUPPLIED WITH THE APPLIANCE MUST BE REPLACED, IT MUST BE REPLACED WITH TYPE 105° C OR ITS EQUIVALENT.
IF THE WIRES MARKED (P) MUST BE REPLACED, THEY MUST BE REPLACED WITH POWER LIMITED FIRE PROTECTIVE CABLE.

STEAM (PZ) BOILER WITH 24V HONEYWELL INTERMITTENT IGNITION, VENT DAMPER AND ELECTRONIC L.W.C.O.

WARNING:

BLOCKED VENT SAFETY SWITCH MUST BE MOUNTED TO DRAFT HOOD BEFORE OPERATING THE BOILER (SEE INSTRUCTION MANUAL GGS-41).
BEFORE INSTALLING VENT DAMPER, READ WARNING LABEL ON THIS BOILER AND VENT DAMPER. READ SLANT/FIN VENT DAMPER INSTALLATION INSTRUCTIONS.
FOR PROPANE USE S8600M OR S8670E ONLY, FOR NATURAL GAS S8600F, S8600M OR S8670E.

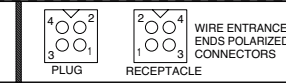
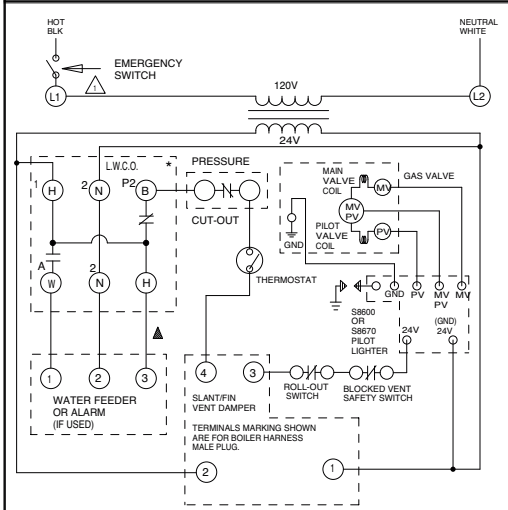
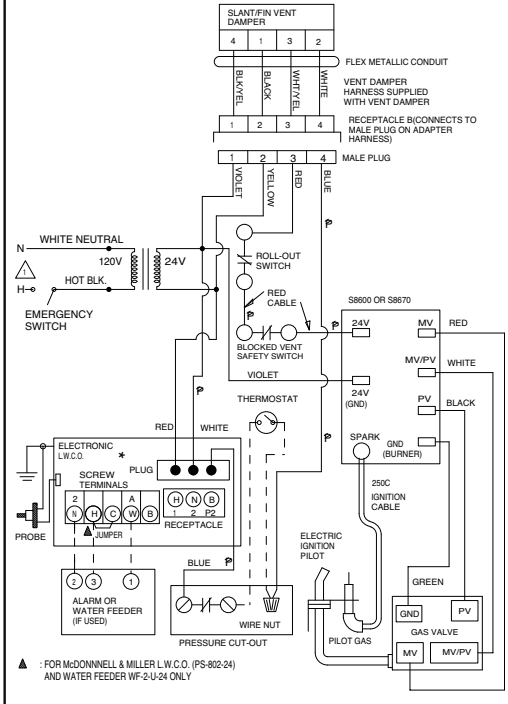

▲ PROVIDE DISCONNECT MEANS & OVERLOAD PROTECTION AS REQUIRED.
IF ANY OF THE ORIGINAL WIRE AS SUPPLIED WITH THE APPLIANCE MUST BE REPLACED, IT MUST BE REPLACED WITH TYPE 105° C OR ITS EQUIVALENT.
IF THE WIRES MARKED (P) MUST BE REPLACED, THEY MUST BE REPLACED WITH POWER LIMITED FIRE PROTECTIVE CABLE.
* TERMINALS MARKING SHOWN IN CIRCLES ARE FOR McDONNELL & MILLER L.W.C.O. THOSE NOT IN CIRCLES ARE FOR HYDROLEVEL (SAFGARD) CONTACTS SHOWN WHEN BOILER WATER IS AT NORMAL LEVEL.

BURNERS FAIL TO OPERATE**CAUSE**

1. Safety pilot out, or flame too low.
2. Gas supply valve shut off.
3. Electric switch open.
4. Blown or defective line fuse.
5. Operating or limit control contacts open or dirty.
6. Defective gas valve or pressure regulator; or plugged bleed line.
7. Defective low voltage transformer.
8. Obstruction at main burner orifice.
9. Break in wiring or loose contact at control terminals.
10. Improper wiring.
11. Improper controls.
12. Rollout or blocked vent safety switch open.

REMEDY

1. Check, clean, re-light. See instructions.
2. Open gas valve(s).
3. Close switch.
4. Replace fuse.
5. Check control. Clean contacts or replace control.
6. Repair or replace.
7. Replace aquastat.
8. Check, clean and reinstall.
9. Check with test-light and correct.
10. Check and correct in accordance with wiring diagrams included with appliance instructions.
11. Install proper controls.
12. Replace rollout switch (inspect flue passages prior to replacement) or reset blocked vent safety switch by depressing the reset button

BURNERS WILL NOT SHUT OFF**CAUSE**

1. Defective operating control, gas valve, or limit control.
2. Improper wiring or short circuit.

REMEDY

1. Check, repair or replace.
2. Check wiring and controls.

FLASH BACK - BURNING AT ORIFICES**CAUSE**

1. Manifold gas pressure too low.
2. Improper primary air adjustment.
3. Gas regulator bleed too slow.
4. Burrs on orifice.
5. Improperly drilled orifice plugs.
6. Leaking automatic gas valve.
7. Adverse draft condition in boiler room.
8. Low main gas pressure.
9. Safety pilot improperly installed.

REMEDY

1. Adjust to proper manifold pressure.
2. Adjust air to produce soft, clean flame.
3. Adjust bleed opening.
4. Remove burrs.
5. Install orifice plugs with proper drilling.
6. Repair or replace.
7. Check air supply and venting system.
8. Contact utility.
9. Correct to manufacturer's recommendations.

DELAYED IGNITION**CAUSE**

1. Pilot flame too low.
2. Pilot burner ports or pilot orifice clogged.
3. Burners or orifices out of alignment.
4. Excessive primary air.
5. Excessive burner input.
6. Adverse draft condition in boiler room.

REMEDY

1. Increase gas supply to pilot.
2. Clean ports or orifices.
3. Realign burners or manifold.
4. Adjust primary air shutters.
5. Check and reduce to input shown on rating plate.
6. Check air supply and venting system.

FUMES AND GAS ODORS**CAUSE**

1. Leaks in gas piping or accessories.
2. Gas leaks in service line or meter connections.
3. Blocked chimney.
4. Boiler flueways blocked with soot.
5. Undersized breeching or too many turns in breeching.
6. Adverse draft condition in boiler room.
7. Overfiring.

REMEDY

1. Locate leaks and repair.
2. Close service supply valve - shut down appliance and notify utility.
3. Check and repair chimney.
4. Clean flueways and adjust burners as described in the installation instructions.
5. Check manufacturer's recommendations.
6. Check air supply and venting system.
7. Adjust gas input to that shown on boiler rating plate.

CONDENSATION IN BOILER FLUES OR IN VENT SYSTEM**CAUSE**

1. Underfiring.
2. Long horizontal run of smokepipe.
3. Inadequate chimney or venting system.

REMEDY

1. Increase firing rate to that shown on rating plate.
2. Relocate boiler or insulate breeching.
3. Check chimney and venting recommendations.

IF REPLACEMENT PARTS ARE NEEDED

When parts are needed, refer to boiler model and serial number shown on the boiler name/rating plate. Refer to the following parts lists for part numbers; publication number GXH-11PL or GXH-12PL for Galaxy GXH Series and GXHA-10PL for GXHA Series boilers. Whenever possible refer to the original order by number and date.

Control identification and replacement should not be attempted by unskilled personnel. Only simple, easily identified controls and parts may be obtained locally. All other controls and parts should be identified by and ordered from Slant/Fin. Relief/Safety valves must be ASME rated for the pressure and gross output of the boiler.

When ordering replacement parts, specify the boiler model number, serial number and gas by name (natural or propane). For replacement parts, heating contractors should contact their Slant/Fin boiler distributor.

APPENDIX A

Removal of Existing Boiler from Common Vent System

"At the time of removal of an existing boiler, the following steps shall be followed with each appliance remaining connected to the common venting system placed in operation, while the other appliances remaining connected to the common venting system are not in operation."

- (a) Seal any unused openings in the common venting system.
- (b) Visually inspect the venting system for proper size and horizontal pitch and determine there is no blockage or restriction, leakage, corrosion and other deficiencies which could cause an unsafe condition.
- (c) Insofar as is practical, close all building doors and windows and all doors between the space in which the appliances remaining connected to the common venting system are located and other spaces of the building. Turn on clothes dryers and any appliance not connected to the common venting system. Turn on any exhaust fans, such as range hoods and bathroom exhausts, so they will operate at maximum speed. DO NOT operate a summer exhaust fan. Close fireplace dampers.
- (d) Place in operation the appliance being inspected. Follow the lighting instructions. Adjust thermostat so appliance will operate continuously.
- (e) Test for spillage at the draft hood relief opening after 5 minutes of main burner operation. Use the flame of a match or candle, or smoke from a cigarette, cigar or pipe.
- (f) After it has been determined that each appliance remaining connected to the common venting system properly vents when tested as outlined above, return doors, windows, exhaust fans, fireplace dampers and any other gas-burning appliance to their previous conditions of use.
- (g) Any improper operation of the common venting system should be corrected so the installation conforms with the National Fuel Gas Code, ANSI Z223.1-latest edition. When resizing any portion of the common venting system, the common venting system should be resized to approach the minimum size as determined using the appropriate tables in Appendix G in the National Fuel Gas Code, ANSI Z223.1-latest edition.



©Slant/Fin Corp. 2019 • PUBLICATION GGS-41 Rev.A • 419 • Part No. 41-0881

SLANT/FIN CORPORATION, Greenvale, N.Y. 11548 • Phone: (516) 484-2600
FAX: (516) 484-0933 • *Canada: Slant/Fin LTD/LTEE, Mississauga, Ontario*

www.slantfin.com