

Slant/Fin®



INTREPID TRDV Series

DIRECT VENT OIL-FIRED WATER BOILER/NO. 2 OIL

SERVICE COMPANY

Name _____

Address _____

Telephone _____

Model # _____

Serial # _____

INSTALLATION AND OPERATING INSTRUCTIONS

READ AND SAVE THESE INSTRUCTIONS FOR REFERENCE.

SAFETY WARNING:

KEEP BOILER AREA CLEAR AND FREE FROM COMBUSTIBLE MATERIALS, GASOLINE AND OTHER FLAMMABLE VAPORS AND LIQUIDS. FAILURE TO ADHERE TO ABOVE SAFETY WARNING, MAY RESULT IN PERSONAL INJURY OR DEATH AND PROPERTY DAMAGE.

CONTENTS	PAGE
Ratings and Dimensions	2
Installation Requirements:	
Boiler Location	3
Clearances	3
Vent Requirements	3
Vent Piping	3
Installing Water trim	3
Piping for Tankless heater	5
Installing Burner	5
Oil Supply Piping	6
Wiring the Boiler	6
Operating Instructions:	
Precautions Before Starting	6
Start-up	6
Cleaning and Filling New Water Boiler	6
Wiring Diagrams	7-9
Burner Data:	
Riello	10
Heatwise	12
Care and Maintenance:	
Extended Shutdown	13
Freezing Protection	13
Oil Burner	13
General Maintenance	13



IMPORTANT: The installation of this equipment must conform to the requirements of the authority having jurisdiction or, in the absence of such requirements, to the Installation of Oil Burning Equipment, ANSI/NFPA 31, latest edition, and to the National Electrical Code ANSI/NFPA 70, latest edition. The installation must also conform to the additional requirements in this Slant/Fin Instruction Manual. Where there is any difference, the more stringent requirement shall govern.

In addition, where required by the authority having jurisdiction, the installation must conform to American Society of Mechanical Engineers Safety Code for Controls and Safety Devices for Automatically Fired Boilers, No. CSD-1, latest edition.

THIS MANUAL MUST BE LEFT WITH OWNER AND SHOULD BE HUNG ON OR ADJACENT TO THE BOILER FOR REFERENCE.

THIS BOILER OPERATES WITH POSITIVE PRESSURE IN THE FLUE AND OVER FIRE, ALL SEALS MUST BE IN PLACE WHEN OPERATING THE BOILER. ALL VENTING MUST BE INSTALLED AND SEALED ACCORDING TO THE VENT MANUFACTURER'S INSTRUCTIONS.

CAUTION

The information in this manual must be followed exactly to avoid personal injury, property damage or loss of life.

IMPORTANT: This boiler must be installed by a trained, experienced, service technician, licensed for the installation and servicing of oil burning equipment or otherwise qualified by the authorities having jurisdiction over the installation.

Tappings and Openings

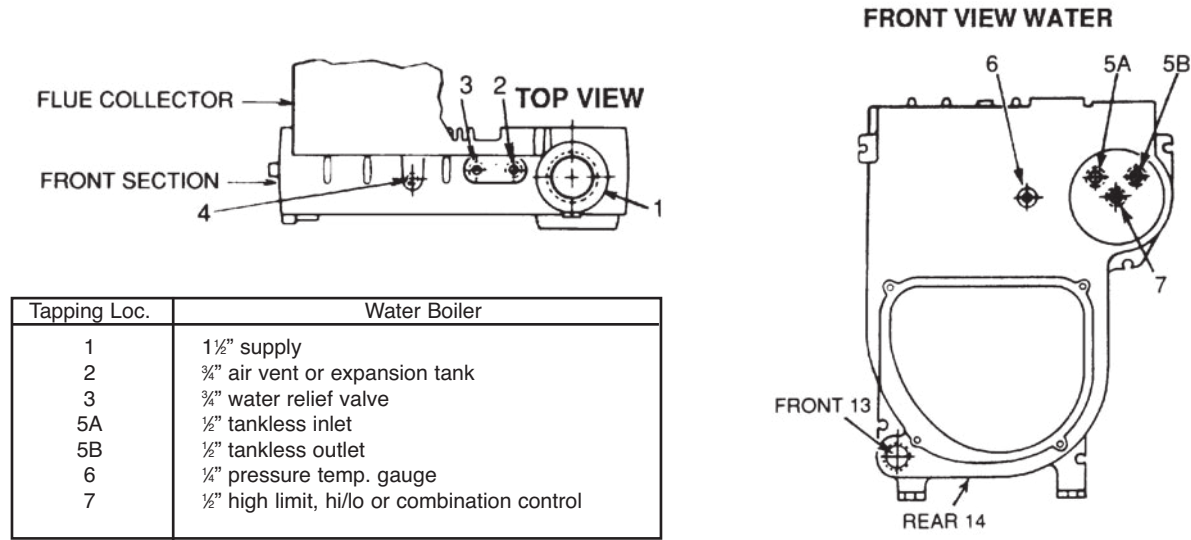

Figure 1

Dimensions

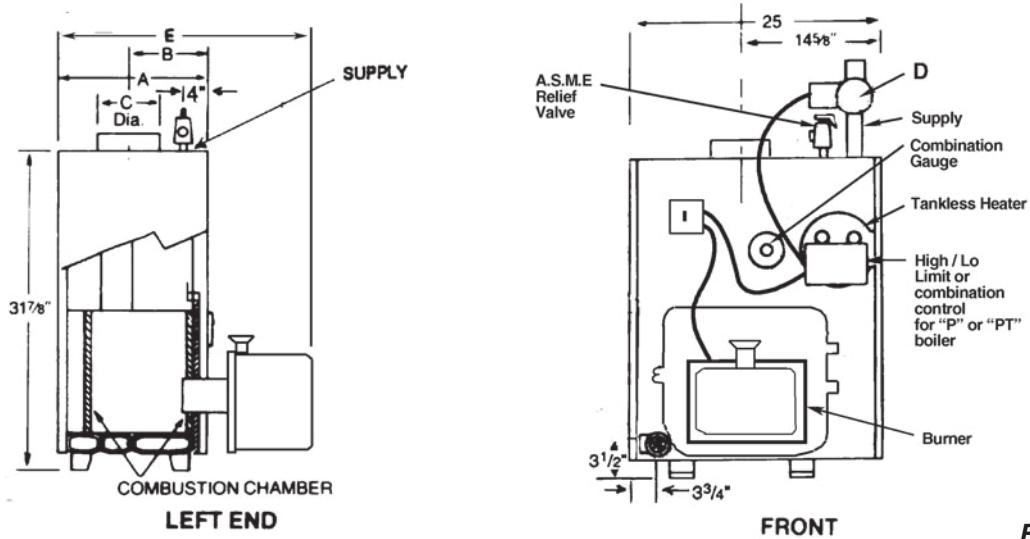

Figure 2

Ratings

Boiler Model*	AHRI Burner Capacity Oil Input		D.O.E. Heating Capacity MBH	AHRI Net Ratings MBH	AFUE%	Dimensions (inches)					Tankless Heater GPM	
	GPH †	BTUH				Water	Water	Water	Boiler Length "A"	Front to Flue "B"		Flue Dia. "C"
TRDV-30-0.85**	0.85	119,000	103	90	87.2	14.875	10.062	6	1.25	27.625	3	3.0
TRDV-30-1.00	1.00	140,000	121	105	86.5	14.875	10.062	6	1.25	27.625	3	3.1
TRDV-30-1.10	1.10	154,000	133	116	86.2	14.875	10.062	6	1.25	27.625	3	3.2

Standard working pressure 30 psi water.

All boilers hydrostatically tested — A.S.M.E.

* For forced hot water heating systems where the boiler and all piping are located within the area to be heated, the boiler may be selected on the basis of gross D.O.E. capacity output. The net AHRI output ratings shown are based on an allowance for piping and pickup of 1.15 (water). D.O.E. capacity gross output is divided by the allowance to obtain net rating. The manufacturer should be consulted before selecting a boiler for unusual piping and pickup requirements such as intermittent system operation, extensive piping, etc.

† Ratings apply to the use of light oil at 140,000 Btu per gallon.

** TRDV-30-0.85 complies with Energy Star 3.0

INSTALLATION REQUIREMENTS

BOILER LOCATION

Provide a level, solid foundation for the boiler.

- A. The foundation must be capable of supporting the weight of the boiler when filled with water:

Boiler Size	Approximate Total Weight of Boiler Assembly, filled with water
TRDV-30	550*

* Without tankless coil

- B. The Intrepid boiler can be installed on both combustible and non-combustible floors, but must NOT be installed on or above carpeting.
 C. The Intrepid Boiler has full wet base sections which surround fire-box for maximum heat absorption of burning fuel, and low floor temperature.
 D. If boiler is to be located over buried conduit containing electric wires or telephone cables, consult local codes or the National Board of Fire Underwriters for specific requirements.

CAUTION: NEVER BURN GARBAGE OR PAPER IN THE UNIT AND NEVER LEAVE COMBUSTIBLE MATERIAL AROUND IT.

MINIMUM CLEARANCE

Provide accessibility clearance of 24" from surfaces requiring servicing (top and front) and 18" on any side requiring passage. The boiler shall be installed with the following MINIMUM clearances from combustible materials: BACK AND SIDES- 6"

NOTE: Except in closets and alcoves, clearances above in (A) and (B) may be reduced by providing forms of protection as specified in NFPA 31, latest edition.

VENTING REQUIREMENTS

- The terminal shall not be closer than 3 feet above or 10 feet horizontally from any forced air inlet into the building.
- The terminal shall not be closer than 4 feet below, 4 feet horizontally or 1 foot above any door, window or gravity air inlet into the building.
- The terminal shall not be less than 3 ft from an inside corner of an "L" shaped building.
- The terminal shall not be less than 7 ft above grade when located adjacent to public walkways.
- The terminal shall not be less than 2 ft from an adjacent building.
- The terminal shall be located at a height not liable to blockage from leaves, snow or other debris, at least 1 ft above grade or anticipated snow line.
- The terminal shall be positioned so that flue gases are not directed where they can jeopardize people, overheat combustible structures or enter buildings.
- Vent terminal should be away from shrubbery or other obstructions that would prevent free air flow to and from vent terminal. Do not terminate vent under decks, stairways or car ports. When ever possible, locations under windows should be avoided.
- Vent termination should not be mounted directly above or within 3 ft horizontally from an oil tank vent.

VENT PIPING

- A. The vent piping minimum bend radius is 12".
 B. Place metal strapping every 36" to support vent pipe and prevent it from sagging.
 C. Maximum wall thickness is 14". Contact Slant/Fin Corp. for recommendations in case of thicker wall.
 D. Gases will form white plume in winter. Plume could obstruct window view.
 E. Prevailing winds could cause freezing of condensate and water/ice buildup on building, plants or roof.
 F. Locate or guard vent to prevent accidental contact by people or pets, and condensate from damaging exterior finish.
 G. Do not terminate vent in window well, stairwell, alcove, courtyard, or other recessed areas.

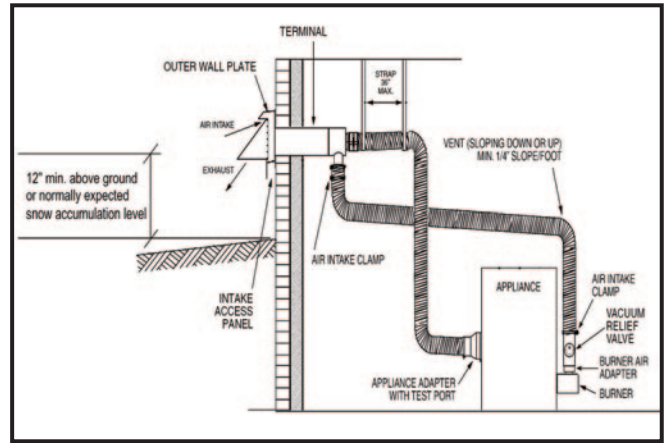

Figure 3. Typical Installation

All venting kits must be double wall construction for the flue gas piping. Flex-L and Field Controls are the two approved manufacturers for venting kits. When installing the vent kits the manufacturers instructions must be followed.

SEE TRDV VENTING INSTALLATION INSTRUCTIONS PUBLICATION NO. TRDV40-V.

INSTALLING WATER TRIM

Notes: Jacket must be installed on boiler units prior to installation of trim.

- I. WATER BOILER TRIM, see page 2 for tapping locations, and figures 1 and 2 for illustration of water boiler.
- Pressure- temperature - Altitude gauge — use tapping no. 6.
 - High temperature limit — use tapping no. 7.
 - Operating control (if used) — use tapping no. 7.
 - Water relief valve — use tapping no. 3, piped full size to boiler.
 - Automatic air vent or compression tank tappings — if used, install in tapping no. 2.
 - Combustion safety control — mounted on burner.

PIPING

IMPORTANT: Boilers are to be used with closed system. Any application that uses steam or water from system, causes the introduction of a frequent supply of fresh water into the boiler. This will cause damage to the boiler. Use of heat exchangers will prevent this damage.

PIPING FOR WATER UNITS

NOTE: On knock down boiler only, jacket may be installed after supply and return piping connection, but must be installed prior to adding trim.

I. CIRCULATING SYSTEM

- FORCED CIRCULATION hot water heating system: Use the top tapping as supply tapping, and use the front or rear bottom tappings for the return.
- A FLOW CONTROL VALVE (See figure 4) will prevent gravity

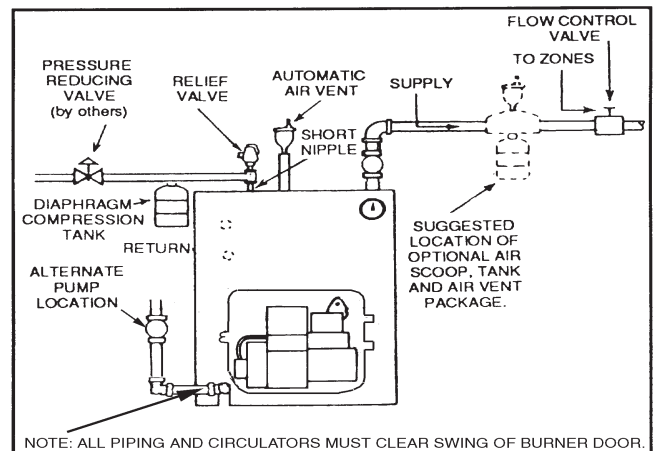
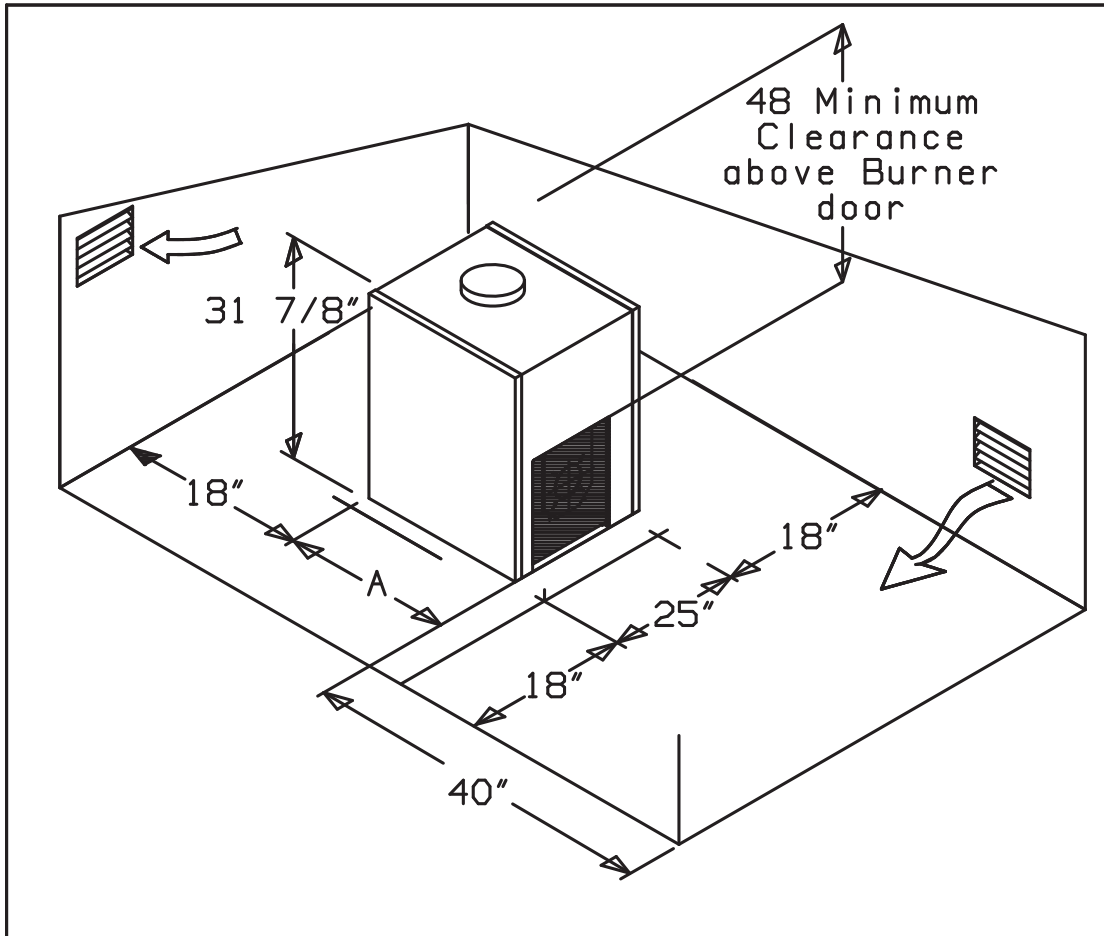

Figure 4. Air Eliminating System

Sufficient space shall be left clear around the boiler.

Do not stack items on or box in the appliance within the required clearances to combustibles.



BOILER MODELS	A (in)
TR-30H / TR(DV)-30 / LD-30	14 $\frac{7}{8}$ "
TR-40H / TR-40 / LD-40	18 $\frac{1}{4}$ "
TR-50H / TR-50 / LD-50	21 $\frac{5}{8}$ "

circulation and usually is required when tankless heater is installed.

II. AIR CONTROL SYSTEMS

- A. DIAPHRAGM-TYPE COMPRESSION TANKS are used to control system pressure in an AIR ELIMINATING SYSTEM: an automatic air vent is used to REMOVE air from the system water. See figure 4. If system pressure needs further control, add an additional tank or install a larger capacity tank. The automatic air vent should be installed in the top of the boiler, as in figure 4.
- B. CONVENTIONAL COMPRESSION TANKS (non-diaphragm type) are used to control system pressure in an AIR COLLECTING SYSTEM. Within the system, after initial start-up and venting, air is collected in the tank and acts in contact with the water to control pressure. Air is not vented from this system. If system pressure needs further control, add another tank in parallel with the original tank or install a large capacity tank. Locate the tank at the inlet end of the pump near the boiler. (See figure 5)
- C. HOT WATER RADIATION VENTING - Manual air vents should be installed at the top of all "drops" (where piping goes downward). Air must be vented or purged from all zone lines to permit proper system heating.
- D. PUMP LOCATION - Locating low-head pump(s) on return to boiler is acceptable for smaller boiler sizes in residences of one or two stories. (See figure 4) The pump location shown in figure 5 is required in large, multi-story building installations, especially when high-head pumps are used.
- E. A conventional compression tank may be connected to the 3/4" tapping as shown in figure 5.

IMPORTANT: Hot water heating systems containing high water volume, such as would occur with cast iron radiation, require special care with air elimination. The circulator pump should be located on the boiler supply pipe and the expansion tank and air scoop should be located near the pump suction. (See Figure 4, Alternate Pump Location.)

PIPING TANKLESS HEATER (if used)

- I. Heater capacities are listed on page 2.
- II. Pipe the built-in tankless heater using the inlet and outlet tapings indicated on the heater (figure 6).
 - A. Tempering valve (illustrated, but not furnished) is suggested to provide more volume of temperate water to kitchen and bath.
 - B. High temperature water, for dishwasher and laundry, may be piped direct.
 - C. A flow control valve should be used to control the rate of flow of water through the coil, otherwise the heating capacity of the coil will be exceeded. To insure sufficient hot water, the flow rate through the coil should be limited to a maximum shown for intermittent draw in the ratings table on page 2.

IMPORTANT: Escape pipes or drain pipes from relief valves, blow-down valves, and low-water cut-offs must be piped off to a safe place.

INSTALLING THE BURNER

See Burner Data, pages 8-11, and Burner Manual supplied with burner. If burner is not mounted as received, mount to boiler, placing flange over mounting studs. Use gasket between flange and boiler. Distance between flange and nose of burner must be as shown on pages 8-11. Check to see that nozzle and settings are as given in burner data tables, pages 8-11.

CAUTION: DO NOT USE GASOLINE, CRANKCASE DRAININGS, OR ANY OIL CONTAINING GASOLINE.

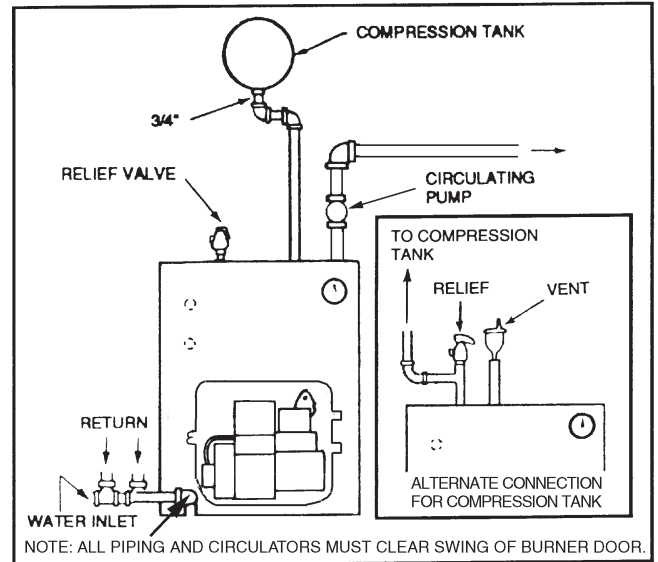

Figure 5. Air Collecting System

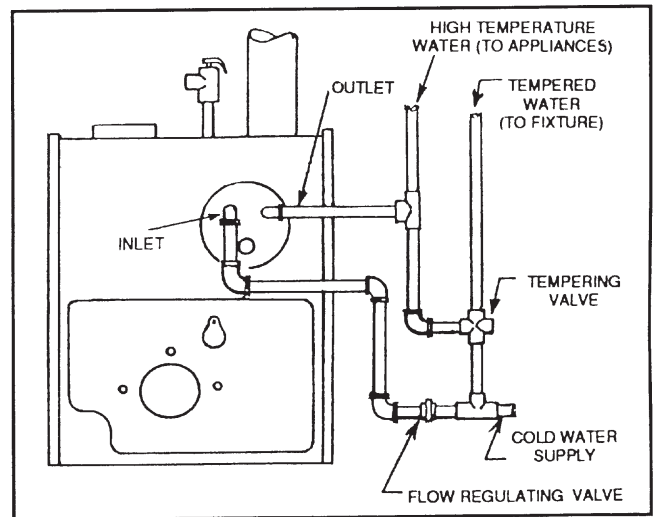

Figure 6. Recommended Piping to Tankless Heater

VOLUME OF WATER IN STANDARD PIPE OR TUBE

Nominal pipe Dia.	Standard Steel Pipe			Copper Pipe	
	Pipe Schedule	Pipe ID Inch	Gal. per Lin.Ft.	Pipe ID Inch	Gal. per Lin. Ft.
3/8	—	—	—	0.430	0.0075
1/2	40	0.622	0.0157	0.545	0.0121
5/8	—	—	—	0.666	0.0181
3/4	40	0.824	0.0277	0.785	0.0251
1	40	1.049	0.0449	1.025	0.0429
1 1/4	40	1.380	0.0779	1.265	0.0653
1 1/2	40	1.610	0.106	1.505	0.0924
2	40	2.067	0.174	1.985	0.161
2 1/2	40	2.469	0.249	2.465	0.248
3	40	3.068	0.384	2.945	0.354

OIL SUPPLY PIPING

Install the oil tank or tanks and piping from tank to burner. Follow local codes and practices, NFPA No. 31, INSTALLATION OF OIL BURNING EQUIPMENT and the instruction sheet attached to the oil burner pump. A one-pipe system should be used for gravity fed fuel systems and for lift systems, where the total lift is less than 8 ft. Where the total lift is greater than 8 ft., a two-pipe system must be used. In some instances, local codes may require a two-pipe system for below grade fuel oil tanks. Be sure to set-up the fuel oil pump for the piping system used; follow the instructions attached to the pump. Be sure to include a good quality, low pressure drop fuel oil filter in the supply line from the tank. This is necessary, especially at low fuel oil flow rates (small nozzle sizes), to prevent nozzle plugging. See Slant/Fin publication on one-pipe and two-pipe fuel oil systems.

WIRING THE BOILER

- The wiring diagrams for the burner and boiler may be found on pages 6-7.
- 24 volt control wiring should be approved Safety Circuit wire, protected as needed.
- Power supply wiring to the burner must be 14 gauge or heavier, as required, and should have a properly fused disconnect switch. 120 volt wiring to pumps and safety controls must also be 14 gauge or heavier. Wire must be enclosed in approved conduit.
- All wiring must be installed in compliance with the National Electric Code, or any local or insurance codes having jurisdiction.

OPERATING INSTRUCTIONS

PRECAUTIONS BEFORE STARTING OIL BURNER

Make a positive check of A through F before starting burner:

- A. Boiler and system are full of water. All air is vented from system. See below.
- B. All wiring is completed. See pages 6-7.
- C. Oil supply is connected to the burner; nozzle is installed correctly; oil valve is open at tank.
- D. All combustible materials are cleared away.
- E. All vent piping is properly installed and sealed.
- F. Burner settings are adjusted as per pages 8-11 and as shown on boiler jacket label.

CAUTION: DO NOT START THE BURNER UNLESS ALL CLEANOUT DOORS ARE SECURED IN PLACE

STARTUP (COMBUSTION TEST INSTRUMENTS MUST BE USED)

- A. Make sure the boiler is installed and wired properly and is full of water.
 - Start the oil burner (see burner instructions for bleeding air from oil, etc.) IMMEDIATELY, set burner air bands to obtain a bright fire with out smoke or oil stain.
 - All readings MUST be taken at the test port in the flue adapter. See Figure 6 for test port location.
 - Smoke reading should be a trace or less on the smoke paper. Adjust the burner as necessary for proper operation.

Note: The draft is not adjustable.
The draft should not exceed 0.35"WC
during burner operation

THE FLUE IS UNDER POSITIVE PRESSURE DURING OPERATION. ALL VENTING MUST BE SEALED AND CHECKED ON A REGULAR INTERVAL.

CLEANING AND FILLING A NEW WATER BOILER**I. BEFORE FILLING WATER BOILER**

- A. Check burner to be certain it is ready for firing. DO NOT FIRE into an empty boiler.
- B. Be prepared to heat raw water to at least 180°F. as soon as it is introduced into the boiler. This procedure will remove dissolved, corrosive gases.
- C. Provide drain line, with valve, from boiler. Use a bottom tapping. Line and drain must be suitable for handling caustic solution.

II. CLEANING WATER BOILER SYSTEM

- A. Prepare a boil-out solution of *sodium hydroxide* (caustic soda) or *tri-sodium phosphate*.

NOTE: Use caution in handling chemicals. Caustic soda is harmful to skin, eyes and clothing.

1. Proportions: 1 lb. of either chemical per 50 gallons of system water.
 2. Stir chemical in water until dissolved and pour into the boiler through a top tapping. Replace plug.
- B. Fill the entire system with water.
 - C. Start the burner, using the start-up procedure.
 - D. Circulate the water through the entire system.
 - E. Vent the system, including the radiation.
 - F. Allow boiler water to reach operating temperature, if possible.
 - G. Continue to circulate the water for a few hours.
 - H. Shut off the burner.
 - I. With CAUTION, drain the boiler solution to a safe location. DO NOT LEAVE SOLUTION SITTING IN SYSTEM OVER 2 HOURS.
 - J. Wash the water side of the boiler thoroughly using a high pressure water stream. Fill and drain the boiler several times.

III. TREATING WATER FOR CORROSION CONTROL

(This is not scale control)

- A. Prepare a solution of *sodium chromate*.
Proportions: 6 oz. per 50 gallons of system water.
- B. Stir chemical into water until dissolved and pour into the boiler through a top tapping. Replace plug.

IV. FILLING AND VENTING THE WATER BOILER

- A. Refill the system with fresh water.
- B. Bring water temperature to at least 180° F. promptly.
- C. Circulate water through entire system.
- D. Vent the system, including the radiation.
- E. The boiler is now ready to be put into service or on standby.
- F. If brand-name air-control devices are used, venting instructions furnished with the devices should be followed.

V. SAFETY CHECK FOR CONTROL SYSTEM

High limit control test: Set thermostat high enough for boiler water temperature to reach high limit control setting. When this temperature is reached, the high limit switch should open, and the burner should shut off automatically. If the high limit does not operate to shut off the burner, the high limit or the wiring is faulty. Repair or replace immediately.

Wiring to the boiler must come through an emergency power isolation switch with a clearly marked red switch plate. This switch should be located so that it is apparent to the homeowner when entering the basement or other boiler area. The homeowner should be made familiar with operating the toggle to provide or stop the power to the boiler.

BASIC WIRING DIAGRAMS FOR
 Honeywell L7248L
 (without tankless heater)
 OR
 Honeywell L7224
 (with tankless heater)
 OR
 HYDROSTAT MODEL 3250
 OR
 BECKETT MODELL 7600A

See page 8 for other Primaries.

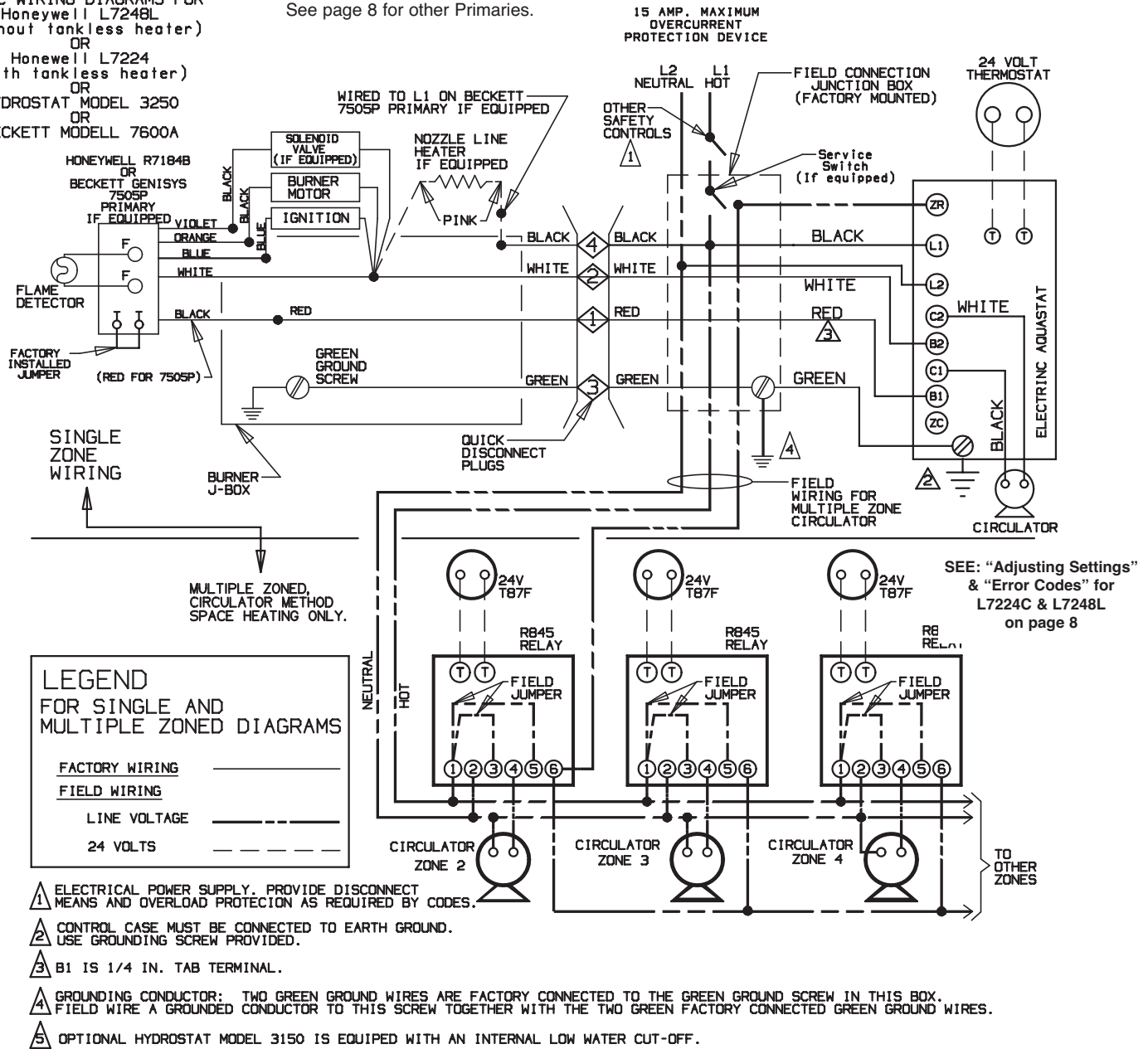

LEGEND FOR SINGLE AND MULTIPLE ZONED DIAGRAMS

FACTORY WIRING	_____
FIELD WIRING	_____
LINE VOLTAGE	-----
24 VOLTS	-----

ZONE WIRING DIAGRAM CIRCULATOR METHOD FOR L8124, L7224 OR OPTIONAL HYDROSTAT #3250 CONTROLS. (FOR TANKLESS HEATER APPLICATIONS)

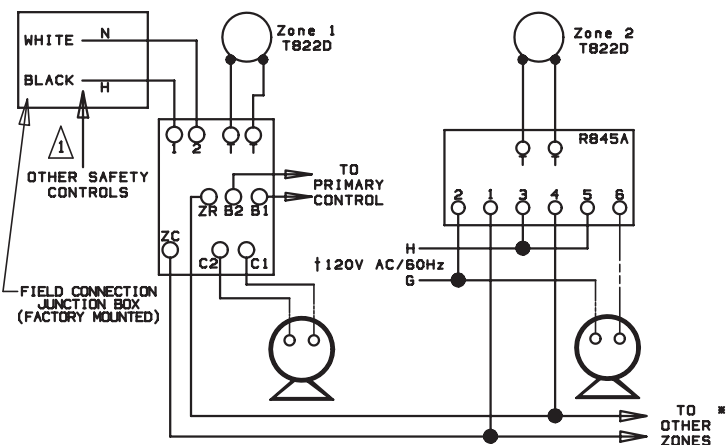

MULTIPLE ZONED, ZONE VALVE METHOD USING HONEYWELL V8043F OR ERIE 765

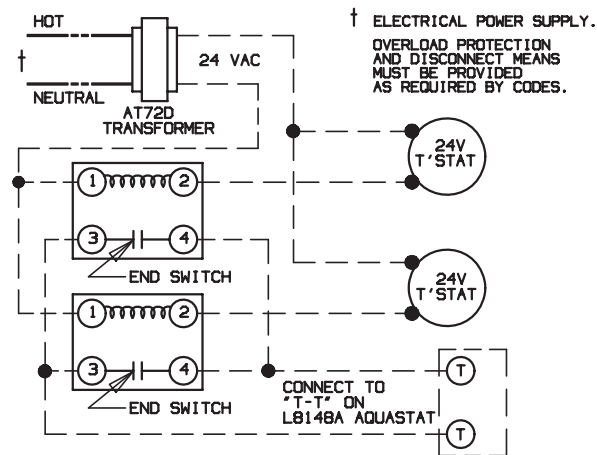

*Note: Total load not to exceed 8 amp full load, for circuits shown.

FOR L7224C OR L7248L

ADJUSTING SETTINGS

To discourage unauthorized changing of Aquastat settings, a procedure to enter the ADJUSTMENT mode is required. To enter the ADJUSTMENT mode, press the UP, DOWN, and I buttons simultaneously for three seconds. Press the I button until the feature requiring adjustment is displayed:

- . HL_ . High Limit.
- . LL_ . Low Limit. (L7224 only)
- . Ldf . Low Limit Differential. (L7224 only)
- . °F . °C.
- . ELL_ External Low Limit (L7248L only)

Then press the UP and/or DOWN buttons to move the set point to the desired value, to change between °F and C°, or to enable (On) or disable (Off) the External Low Limit. After 60 seconds without any button inputs, the control will automatically return to the RUN mode.

DISPLAY

In the RUN mode, the Aquastat will flash .bt. (boiler temp) followed by the temperature (i.e., 220), followed by °F or °C.

To read boiler settings, press the I key to read the parameter of interest. For example, press I High Limit (HL) is displayed, followed by a three-digit number, i.e., 220, followed

by °F or °C. Pressing the I button again (on L7224 models) will display the Low Limit (LL) followed by a three-digit number and the corresponding degree designator.

After approximately 60 seconds without any key presses, the display will enter a dim display mode. To return to the bright display mode, simply press any key.

DESCRIPTION

- Boiler Temperature – bt
- High Limit – HL
- Low Limit – LL
- Low Limit Differential – Ldf
- Local Thermostat Status – tt
- Enviracom Thermostat Status – tte
- Error Code – Err
- Degrees Fahrenheit – °F
- Degrees Celsius – °C

Aquastat Error Code	Cause/Action	EnviraCOM Alarm
Err1	Aquastat sensor fault; check water sensor.	18
Err2	ECOM fault; check EnviraCOM™ wiring.	18
Err3	Excessive electrical noise or frequency out of range. Hardware fault; replace controller.	18, 58
Err4	B1 fault; check B1 wiring/voltage.	64
Err5	Low Line; check L1-L2, 110 Vac.	59
Err6 ^a	Warning: Fuse; check ECOM wires, replace fuse.	92
Err7	Warning: EEPROM, HL, LL, Hdf, Ldf; reset to default values.	N/A
Err 8 ^b	Repeated B1 fault (voltage present at B1 when output is turned off); check B1 wiring/voltage.	25
Err9 ^a	Warning: Outdoor Reset System failure; communication to Outdoor Reset Module lost, Outdoor Reset Module failure, multiple outdoor temperature sensors detected on the bus, or outdoor temperature sensor failure. Check EnviraCOM wiring (1, 2, 3), check sensor wiring.	50, 53, 149
Err 10 ^a	Warning: Boost Failure; Boost Mode active at least once per cycle for the last 60 consecutive cycles. Check Outdoor Reset curve settings.	150
Err 11 ^a	DHW Module/Sensor failure; communication to DHW Module lost, DHW Module failure, or temperature sensor failure. Check EnviraCOM wiring (1, 2, 3), check sensor wiring.	146, 147, 148

^a Warnings are generated to enunciate the system is not operating optimally, but the Aquastat is still operating and maintaining boiler temperature. In the instance where an Outdoor Reset Module is used, the warnings may indicate a reset curve setting error one or more features is not running optimally, and the Aquastat is reverting to default settings or has stopped running the Outdoor Reset algorithms. The warnings are cleared when the issue(s) is resolved.

^b To clear Err 8 condition, depress and hold all three user keys simultaneously for 60 seconds. Err 8 condition clears and display returns to normal. Err 8 condition is designed to catch welded relays on the Aquastat and will normally only occur near end of life for the control. If Err 8 condition has occurred early in the controls life, be sure to check for voltage feedback to B1 when B1 should be off and check current draw on b terminal to be sure oil burner is not drawing excessive current. Err 8 condition will keep repeating if B1 fault is not cleared.

IMPORTANT

This boiler is equipped with a feature that saves energy by reducing the boiler water temperature as the heating load decreases. This feature is equipped with an override which is provided primarily to permit the use of an external energy management system that serves the same function. **THIS OVERRIDE MUST NOT BE USED UNLESS AT LEAST ONE OF THE FOLLOWING CONDITIONS IS TRUE:**

- An external energy management system is installed that reduces the boiler water temperature as the heating load decreases.
- This boiler is not used for any space heating
- This boiler is part of a modular or multiple boiler system having a total input of 300,000 BTU/hr or greater.
- This boiler is equipped with a tankless coil.

BASIC WIRING DIAGRAMS

L7224C OR L8124C OR A
(WITH TANKLESS HEATER)

NOTES:

1. RECOMMENDED HIGH LIMIT SETTING IS 200°F. LOW LIMIT MUST BE SET AT LEAST 20°F BELOW HIGH LIMIT SETTING.
 2. PUMP ZONING TERMINALS ZR AND ZC FURNISHED ON L8124 AND L7224C CONTROLS. SEE PUMP ZONING DIAGRAM BELOW
- † OVERLOAD PROTECTION AND DISCONNECT SWITCH MUST BE PROVIDED AS REQUIRED BY LOCAL CODES.

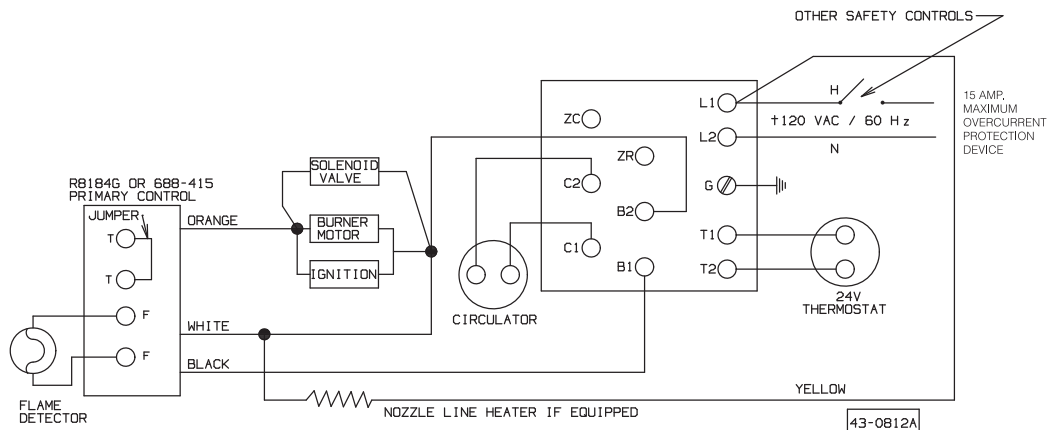

Basic Module Wiring (less circulator)

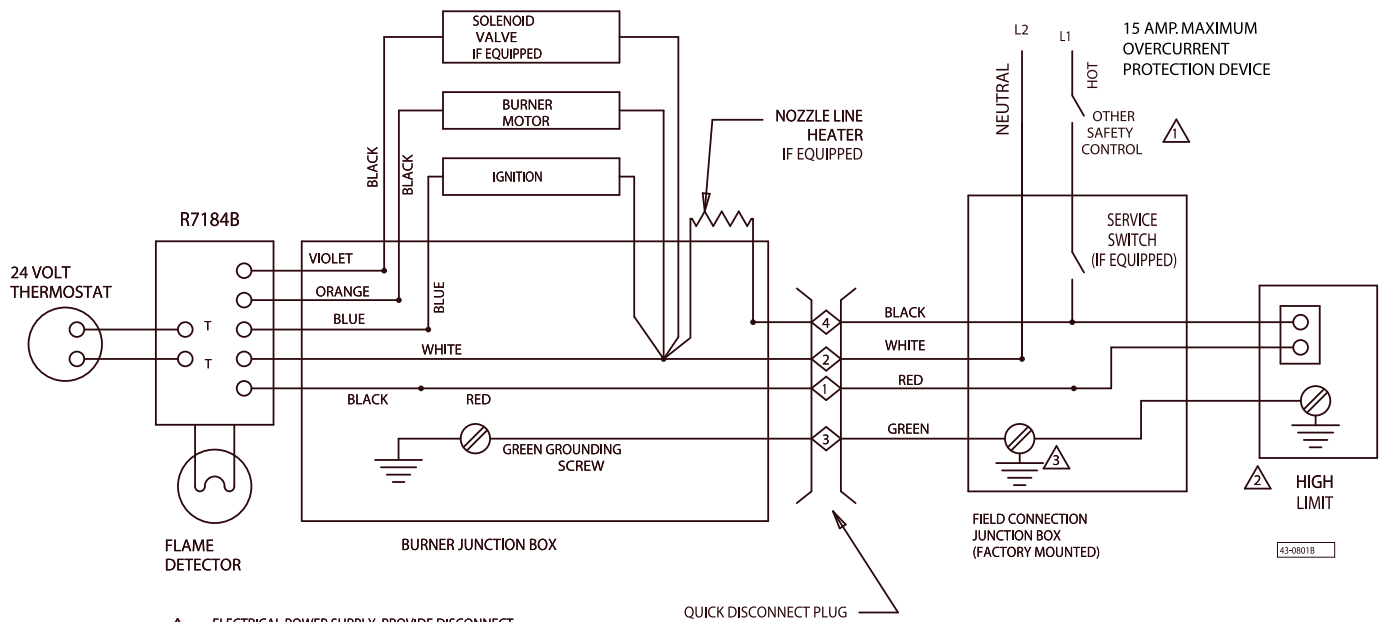

- ⚠️ 1 ELECTRICAL POWER SUPPLY. PROVIDE DISCONNECT MEANS AND OVERLOAD PROTECTION AS REQUIRED BY CODES.
- ⚠️ 2 CONTROL CASE MUST BE CONNECTED TO EARTH GROUND USE GROUNDING SCREW PROVIDED.
- ⚠️ 3 GROUNDING CONDUCTOR: TWO GREEN GROUND WIRES ARE FACTORY CONNECTED TO THE GREEN GROUND SCREW IN THIS BOX. FIELD WIRE A GROUNDED CONDUCTOR TO THIS SCREW TOGETHER WITH THE TWO GREEN FACTORY CONNECTED GREEN WIRES.

43-0801B

RIELLO BURNER DATA – BURNER MODEL BF-5

Boiler Model	Riello Burner Model	Firing Rate No. 2		Nozzles			Oil Pump Pressure Setting	“A” Approx. Head	Approx. Air Band Opening
		GPH	L/Hr	Size (GPH)	Angle & Type	Mfg.			
TRDV-30-0.85	BF-5	0.85	3.21	0.65	70 W	Delavan	170	0	3.1
TRDV-30-1.00	BF-5	1.00	3.78	0.85	70 W	Delavan	140	0	4
TRDV-30-1.10	BF-5	1.10	4.16	0.85	70 W	Delavan	170	1	4

Model BF-5 Electrode Setting

Proper Insertion into Combustion Chamber

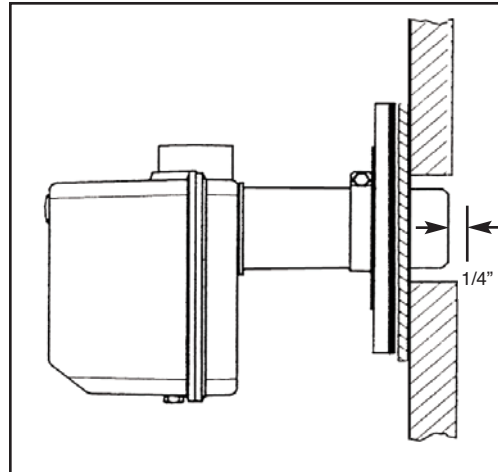
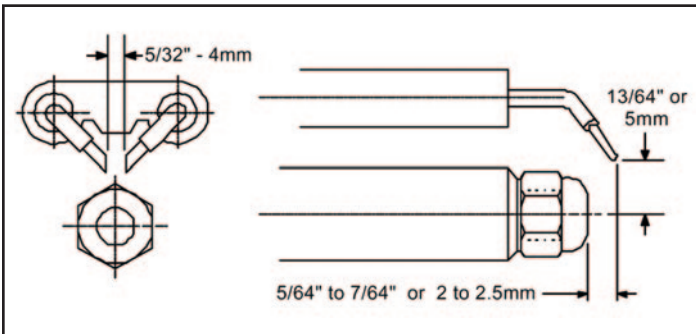

Figure 7

Figure 9

Turbulator Setting

Turbulator location

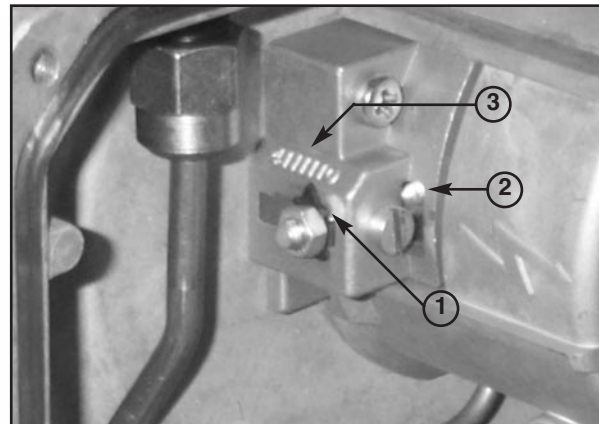
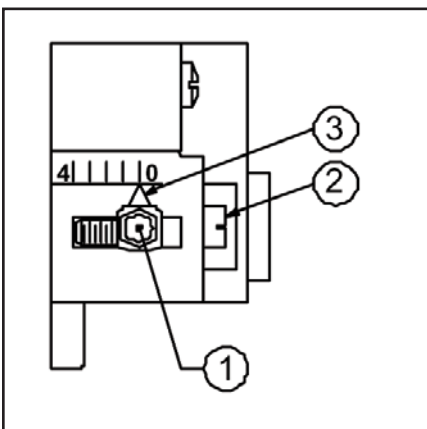

Figure 8

Picture 1

TURBULATOR SETTING

1. Loosen nut, 1, then turn the screw, 2, until the index marker, 3, is aligned with the correct index number.
2. Retighten the retaining nut, 1.

The numbers on the casting are there to denote the high and low end of the scale – For Model BF-5, zero and four are scale indicators only. From left to right, the first line is 4 and the last line is 0.

The air/oil ratio depends on accurate setting of the turbulator disc and air damper.

Be careful when making this adjustment as an incorrect setting will result in an unsatisfactory operation. See figure 8 & 9.

SETTING THE AIR DAMPER ADJUSTMENT (see figure 10 & picture 2)

1. The initial air damper setting is made by turning screw (2) until the top edge of the air damper (3) is aligned with the number according to the burner setup chart.
2. Further adjustments can be made with the burner cover in place by removing plastic plug on the top right hand side of the cover. Turn the screw counter clockwise (+ indicator) to increase combustion air, turn the screw clockwise (- indicator) to decrease combustion air.
3. The final position of the air damper will vary on each installation. Use instruments to establish the proper settings for maximum CO₂ and a smoke reading of trace to zero.

NOTE: Variations in flue gas, smoke, CO₂ and temperature readings may be experienced when the burner cover is put in place. Therefore, the burner cover **MUST** be in place when making the final combustion instrument readings, to ensure proper test results.

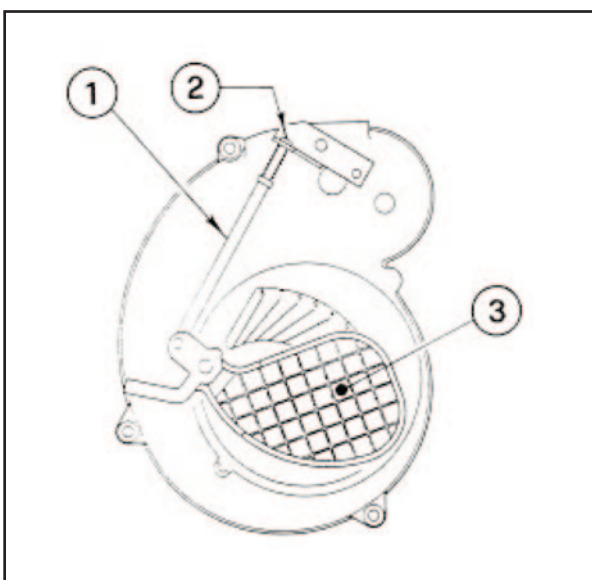
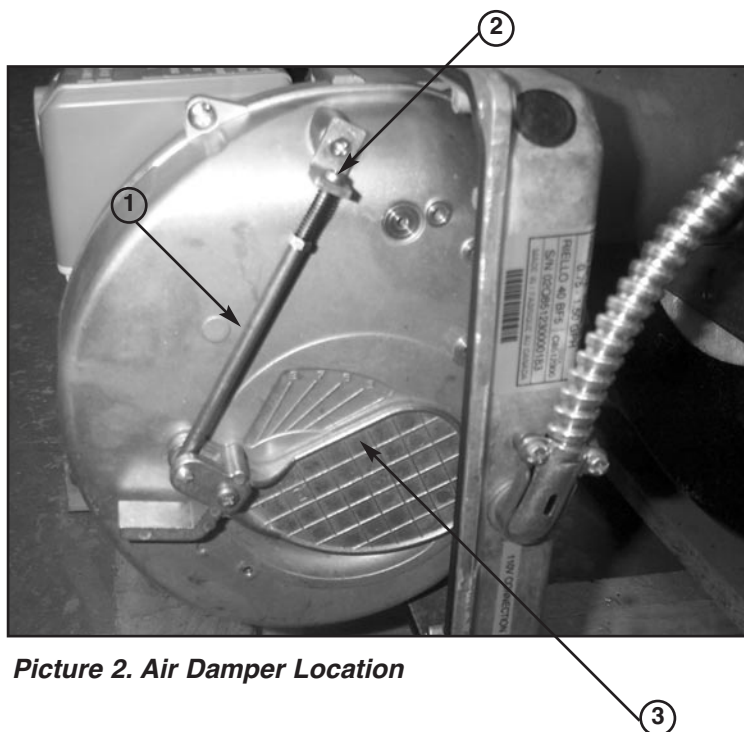

Figure 10 Air Damper Setting



Picture 2. Air Damper Location

CARE AND MAINTENANCE

CAUTION: DO NOT ATTEMPT TO START THE BURNER WHEN EXCESS OIL HAS ACCUMULATED, WHEN THE UNIT IS FULL OF VAPOR, OR WHEN THE COMPBUSTION CHAMBER IS VERY HOT.

CAUTION: DO NOT TAMPER WITH THE UNIT OR CONTROLS—CALL YOUR SERVICE PERSONNEL.

I. EXTENDED SHUTDOWN, CLEANING OR REMOVAL OF BOILER FROM SERVICE.

DANGER: Use CAUTION when handling chemicals and draining hot water from a boiler. Scalding water and/or chemicals can cause permanent injury to the skin, eyes and respiratory system.

A. Shut down burner by disconnecting all electrical power to the burner by turning OFF the BURNER EMERGENCY SWITCH of this boiler. After shutting down burner, while the boiler is still hot (180°F to 200°F), drain water from the bottom of the boiler until it runs clear.

B. To clean the fireside boiler surfaces, first shut down burner by disconnecting all electrical power to the burner by turning OFF the OIL BURNER EMERGENCY SWITCH of this boiler in order to perform the following work in (1) through (10) below.

1. Remove the flue pipe from the boiler flue collar and clean thoroughly.

2. Inspect the entire vent connector back to the chimney and clean if necessary.
3. Inspect the chimney for soot, debris and other unsafe conditions of the chimney and take the necessary action.
4. Remove the flue collector by first removing the top jacket panel. The flue collector is held in place by a 10-32 Hex Nuts. Remove the Hex Nuts and carefully remove the flue collector. Try not to disturb the seal under the flue collector.
5. When necessary to clean the combustion chamber you must first CLOSE the suction valve (and return valve if two pipe). Then disconnect the oil lines from the burner. The flexible electric conduit connected from the junction box on the boiler to the burner via a plastic connector must be disconnected from the burner by grasping the plastic half of the connector closest to the flexible conduit and gently pulling it in the direction of the conduit until it is disconnected. Remove the single 3/8-16 hex head screw on the LEFT side of the swinging door. You will need a 9/16" drive socket. Open the door to completely expose the combustion chamber for thorough cleaning and for inspection of target wall, blanket (provided in certain models; see rating plate), main cast iron burner door insulation and burner door fiberglass sealing rope. If combustion chamber parts above are badly deteriorated then replace with original factory

parts available at your distributor.

6. Remove the Baffles from between the casting sections. Use the flue brush to clean the pinned flue ways between the sections.† A wire brush may be used to remove any carbon accumulation that may have developed in the combustion chamber. Vacuum the loose soot and debris from the boiler. Reinstall all flue Baffles between the casting sections.
7. Inspect the burner combustion head. Clean if necessary and make sure all the adjustments are correct. (See burner data pages for the burner installed.) Replace oil nozzle with new one and readjust electrodes. To insure proper burner operation **ONLY THE NOZZLES SPECIFIED IN THIS MANUAL OR ON THE BURNER LABEL SHOULD BE USED FOR REPLACEMENT.**
8. Protect all of the fireside surfaces by swabbing with neutral mineral oil.
9. Close main cast iron burner door (door on which burner is mounted). Make sure that the entire seal (fiberglass rope) is making good contact with the boiler casting when replacing 3/8-16 x 1" long hex head bolt and tightening.
10. Check the flue collector seal. This is the High Temp. silicone seal on top of Flue Collector base. The seal must be in place over the 10-32 Studs. Use the 10-32 Hex Nuts to refasten the flue collector top. In order to assure a proper seal be sure that the seal is pressed tight between the flue collector base and top. Be careful not to over tighten the 10-32 nuts as this will cause the flue collector to become distorted.

C. If boiler room is damp, provide ventilation.

CAUTION: ALWAYS KEEP THE OIL SUPPLY VALVE SHUT OFF IF THE BURNER IS SHUT DOWN FOR AN EXTENDED PERIOD OF TIME.

II. PROVIDING PROTECTION FOR FREEZING

Anti-freeze is sometimes used in hydronic heating systems to protect against freeze-up in the event of power failure, or safety control shutdown when the building is unoccupied. It should be recognized that unless the building is kept above freezing temperature by some means, the plumbing system is not protected.

PROPYLENE GLYCOL is used in the quick-freeze food industry; it is practically non-toxic. Its use may be permitted when tankless heaters are used. When anti-freeze must be used, inhibited propylene glycol is recommended. Useful information on the characteristics, mixing proportions, etc. of glycol in heating systems is given in Technical Topics No. 2A, available from the Hydronics Institute, 35 Russo Place, Berkeley Heights, N.J. 07922. Consult glycol manufacturers for sources of propylene glycol. **DO NOT** use ethylene glycol

because it is toxic.

III. OIL BURNER

All service to the oil burner, oil filter, oil strainers, etc., should be performed by a professionally trained service person. Inspect and clean annually and following any period of improper operation. Recheck and adjust settings as specified for burner model and nozzle size. Set burner air and draft regulator, using test instruments to obtain recommended CO₂ and draft without smoke. Refer to page 5.

IV. GENERAL MAINTENANCE

These operations are recommended to be performed at regular intervals:

- A. **BOILER HEATING SURFACES:** clean off all coatings found. Reseal covers.
- B. **BOILER CONTROLS:** check contacts, settings, correct functioning.
- C. **PIPING:** check piping and accessories for leaks.
- D. **CHIMNEY or STUB VENT and BREECHING:** check for obstructions and leaks.
- E. **COMBUSTION AIR TO BURNER:** check for continued POSITIVE supply of air as required. Air needs are greatest in coldest weather. Refer to AIR SUPPLY, page 3.
- F. **WATER SYSTEM:** check
 1. System to be full of water and pressure to remain stable (between 12 psi and 25 psi).
 2. Air-control system: noise and air binding in radiation should not occur.
 3. Water lines: slightest leaks should be corrected.
 4. Low water cut-off, for operation (see instructions furnished with unit). See page 9.
- G. **BOILER ROOM AIR SUPPLY:** air vents terminal should be open and free of obstruction. See page 3.

† A flue brush (2-1/4" dia.) is supplied with boiler. Replacements are available from dealer or hardware stores.

BAFFLE LAYOUT CHART

"L" BAFFLE P/N 430885000
 "T" BAFFLE ASSY. P/N 430886020

	BAFFLES BETWEEN FRONT & REAR SECT.	BAFFLES BETWEEN FRONT & CENTER SECT.	BAFFLES BETWEEN CENTER SECTIONS	BAFFLES BETWEEN CENTER & REAR SECT.
TR/LD-20	1 X "L" BAFFLE			
TR/LD/TRDV-30		1 X "L" BAFFLE		1 X "T" BAFFLE
TR/LD-40		1 X "L" BAFFLE	1 X "T" BAFFLE	1 X "T" BAFFLE
TR/LD-50			2 X "T" BAFFLE	1 X "T" BAFFLE
TR/LD-60			3 X "T" BAFFLE	1 X "T" BAFFLE
TR/LD-70			4 X "T" BAFFLE	1 X "T" BAFFLE

