

User's Information Manual

VICTORY VSPH SERIES GAS BOILERS

Sealed Combustion - Direct Vent Models

FOR YOUR SAFETY:

- Before operating this boiler, READ this manual.
- DO NOT attempt to install, service or repair this boiler yourself. There are no user serviceable parts. Contact a qualified service agency if your boiler needs repair or maintenance. Ask your gas supplier for a list of qualified service agencies.
- A qualified service agency should inspect the venting system of this boiler on an annual basis.



WARNING: If the information in this manual is not followed exactly, a fire or explosion may result causing property damage, personal injury or loss of life.

___ **DO NOT** store or use gasoline or other flammable vapors and liquids in the vicinity of this or any other appliance.

WHAT TO DO IF YOU SMELL GAS

- **DO NOT** try to light any appliance.
- **DO NOT** touch any electrical switch
- **DO NOT** use any phone in your building.
- Immediately call your gas supplier from a neighbor's phone. Follow the gas supplier's instructions.
- If you cannot reach your gas supplier, call the fire department.

___ Installation and service must be performed by a qualified installer, service agency or the gas supplier.

Your gas boiler must be installed and serviced by a qualified service agency or gas supplier. The lack of proper service can result in a dangerous condition.

This manual must be left with owner, hung on or adjacent to the boiler. Owner should retain manual for future reference.

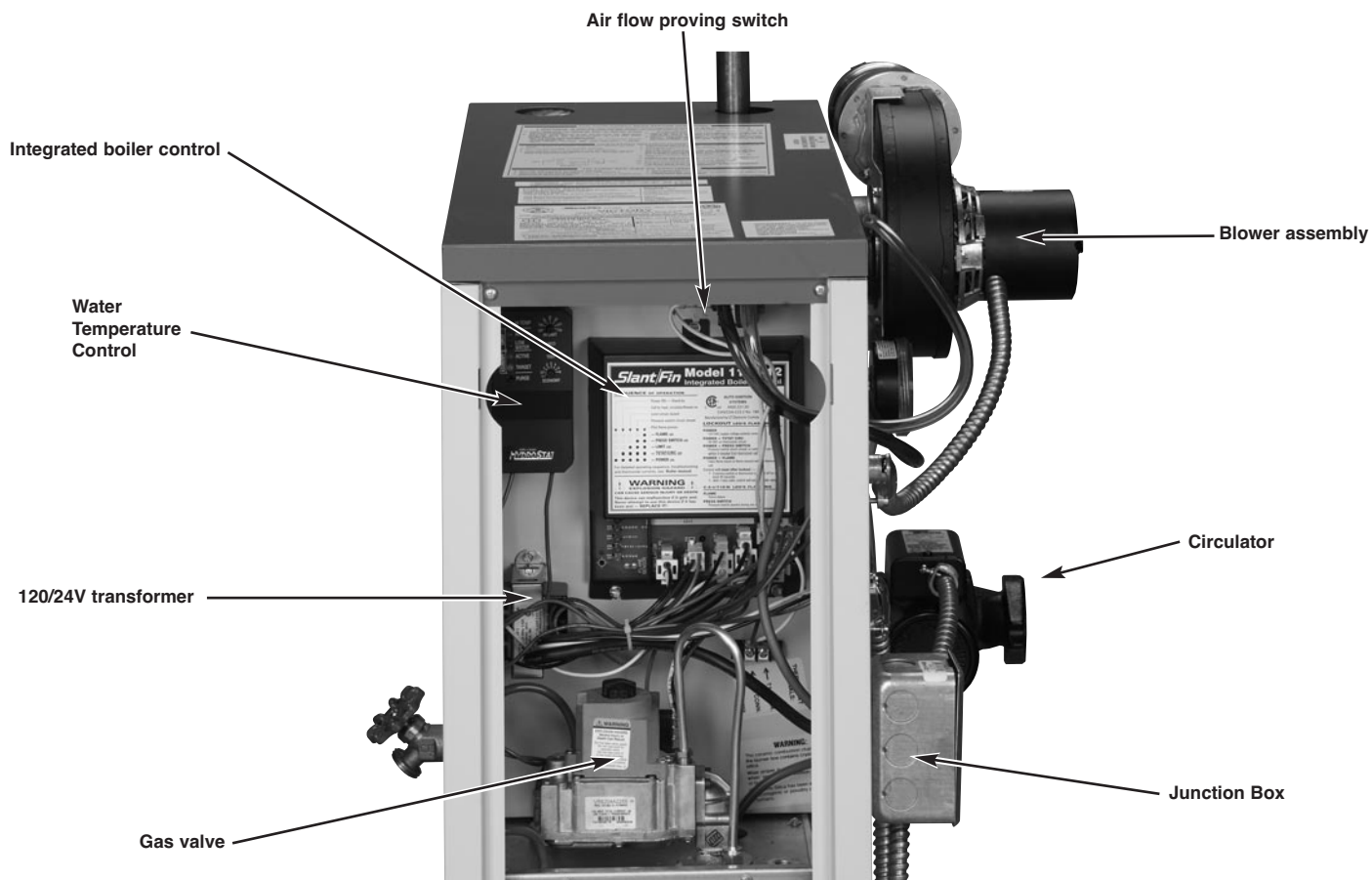

Figure 1. Location and Identification of parts.

WELCOME TO OUR VALUED CUSTOMER

You are now the owner of a Slant/Fin Victory VSPH gas-fired boiler, another quality heating product designed and manufactured by an industry leader, to provide your family with many years of reliable comfort and trouble-free performance.

The care and maintenance of your new boiler is important to prevent a hazardous condition which might result from lack of proper servicing. Therefore, you should perform regular “owner” inspections as described in this manual (and report any concerns to a qualified service technician) as well as have your boiler serviced by a qualified service technician at least once a year, preferably before the beginning of each heating season.

LIGHTING INSTRUCTIONS

Locate, read and then follow the procedures on the lighting instructions label attached to the boiler. For reference, we

DO NOT use this boiler if any part has been underwater. Immediately call a qualified service technician to inspect the boiler and to replace any part of the control system and any gas control which has been underwater.

WARNING

Should overheating occur or the gas supply fail to shut off, DO NOT turn off or disconnect the electric supply to the circulator pump. Instead, shut off the gas supply at a location EXTERNAL to the appliance.

WARNING

SLANT/FIN DOES NOT PERMIT THE USE OF VENT DAMPERS ON VICTORY SERIES BOILERS. OTHER DAMPERS OR DEVICES WITH SIMILAR PURPOSE ARE NOT PERMITTED.

Keep the boiler area clean and free of all materials that can burn.
NEVER close or reduce openings that supply air for the boiler fire and for ventilation.

INSPECTION

Your boiler and heating system will last an indefinitely long time at full efficiency, if it is inspected regularly and is kept in good repair and adjustment. You, the user, should make regular inspections, and report any problems to your service agency. At regular intervals, you should have that agency inspect the system, clean the boiler and make repair adjustments as necessary. What you and the service agency should do is listed below. Contact your gas supplier for a list of qualified service and repair agencies.

USER INSPECTION

The user should make the following inspections at least once each month during the heating season and once just before cold weather starts. VSPH boilers maybe installed and vented either as direct-vent boiler, which all air for combustion is obtained directly from outside through the air intake piping or as non-direct-vent boiler, which all air for combustion is taken from inside the boiler room. Typical direct-vent installations are shown on Figures 2 and 3. Non-direct-vent installation is shown on Figures 4, 5 and 6.

1. VENTING AND AIR INTAKE SYSTEM REGULAR INSPECTION

Inspect the system regularly for condensation, corrosion and/or physical damage. A qualified professional should service the boiler annually and include such an inspection at that time. The homeowner should look over the system monthly for damage, water stains, any signs of rust, other corrossions or separation of the vent and air

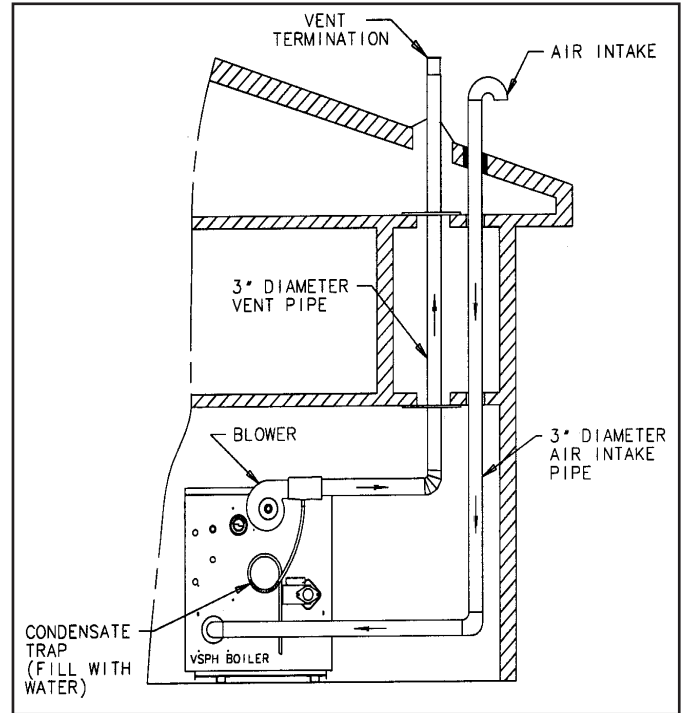

Figure 3.

intake piping (if direct-vent).

Should an inspection turn up signs of condensation, corrosion or damage, the boiler should be shut down immediately and the condition should be corrected by a qualified professional.

If the boiler is vented horizontally through the wall, the outside termination, louvers and screen should be checked for any debris blocking the opening and cleaned as

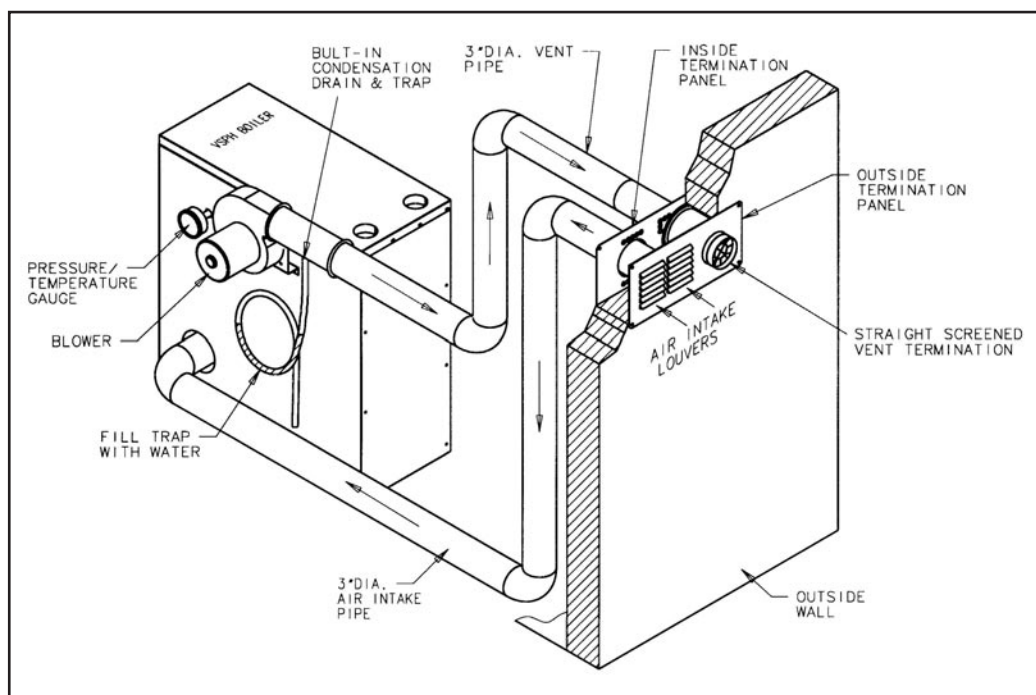

Figure 2.

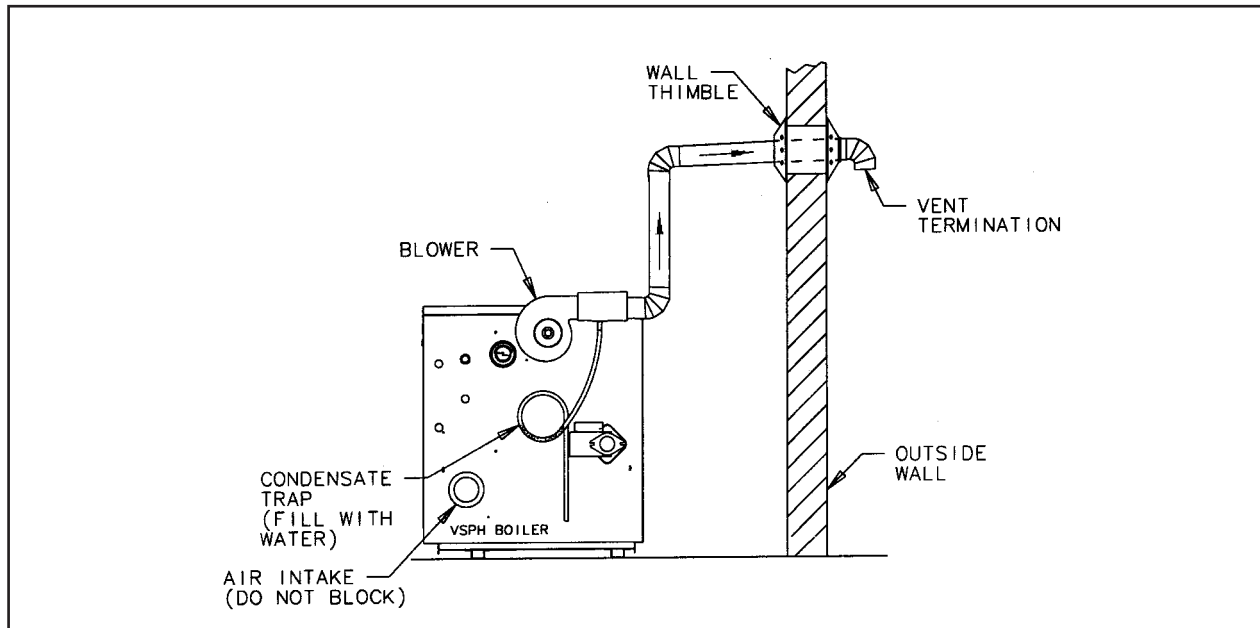

Figure 4.

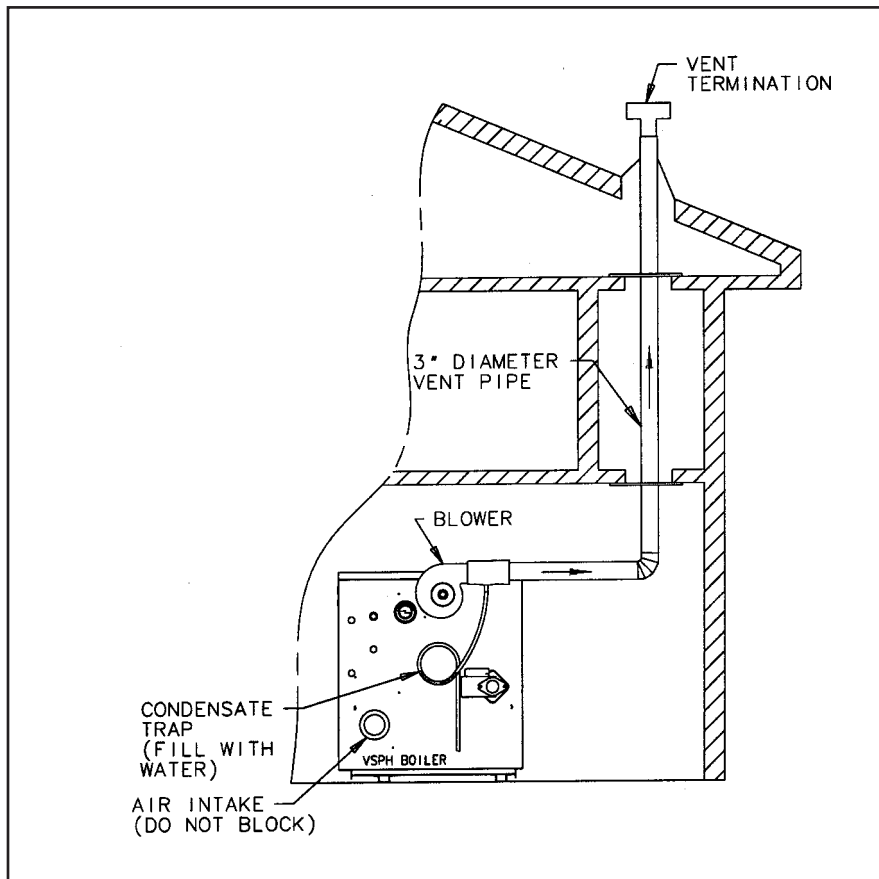

Figure 5.

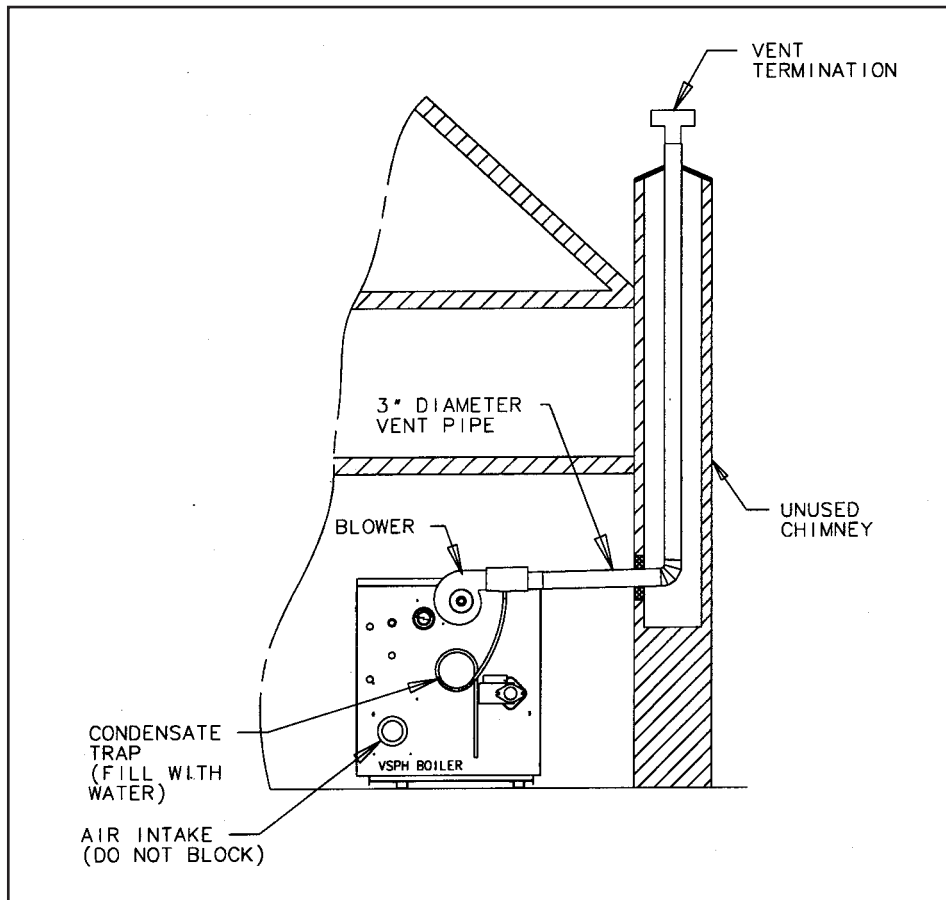

Figure 6.

2. CONDENSATION DRAIN

All Victory VSPH boilers are equipped with a built-in condensation drain and trap. The trap loop must be filled with water. DO NOT operate the boiler without filling the trap with water to prevent flue gas discharge into space. Periodic inspection should be made of this assembly for deterioration of the tubing and to insure that the trap is not plugged. If it is plugged or appears to have excessive sediment in it, it should be removed from the drain assembly, straightened out to clear the obstruction, reformed, filled with water and reinstalled as before.

3. PIPING INSPECTION

Look at all water piping. There should be no leaks or signs of leaks at any pipe joints or around the boiler.

4. SYSTEM WATER PRESSURE INSPECTION

The temperature and pressure gauge indicates the pressure in the boiler at each water temperature. For most installations, it should indicate about 12 to 15 psi pressure when temperature is about 70 to 100F and from 15 psi to 25 psi when temperature is up to 240F. FOR YOUR SYSTEM, there is one correct pressure for each temperature. ASK YOUR INSTALLER OR SERVI-

CEPERSON TO EXPLAIN AND SHOW YOU. Learn what normal pressure to look for. If pressure rises from normal, the relief valve will open to relieve the pressure. Call your service organization if pressures are higher or lower than normal, and if the relief valve spills water. Repair or adjustment is needed.

5. UNUSUAL NOISE

Stand near the boiler and look and listen. As the burners start and shut off, there should be no unusual noise.

6. BOILER ROOM AIR SUPPLY

Ample boiler room fresh air is required for combustion (non-direct vent installation) and ventilation (direct-vent installation).

Check air vents for continuous positive supply of air as required. Air needs are greatest in cold weather if boiler

Warning: The flow of combustion and ventilating air to the boiler should not be obstructed.

Warning: If you find any problem during your inspection, call for service immediately.

installation is non-direct vent method. Air vents must be open and free of obstruction.

ANNUAL SERVICE AND GENERAL MAINTENANCE

A trained and qualified service technician should perform inspection and general maintenance listed in Installation and Operating Instructions (Publication No. VSPH-40) before each heating season and at regular intervals.

SAFETY AND OPERATING INSTRUCTIONS

Follow the lighting instructions in this manual. These instructions are also attached to the boiler.

WARNING: If you do not follow these instructions exactly, a fire or explosion may result causing property damage, personal injury or loss of life.

SAFETY INFORMATION

For Your Safety Read Before Operating

- A. This appliance is equipped with an ignition device which automatically lights the pilot. **DO NOT** try to light the pilot by hand.
- B. **BEFORE OPERATING** smell all around the appliance area for gas. Be sure to smell next to the floor because some gas is heavier than air and will settle on the floor.

WHAT TO DO IF YOU SMELL GAS:

- **DO NOT** try to light any appliance.
 - **DO NOT** touch any electric switch: **DO NOT** use any phone in your building.
 - Immediately call you gas supplier from a neighbor's phone. Follow the gas supplier's instructions.
 - If you cannot reach your gas supplier, call the fire department.
- C. Use only your hand to turn the gas control knob. Never use tools. If the knob will not turn by hand, don't try to repair it, call a qualified service technician. Force or attempted repair may result in a fire or explosion.
 - D. **DO NOT** use this appliance if any part has been under water. Immediately call a qualified service technician to inspect the appliance and to replace any part of the control system and any gas control which has been under water.

OPERATING INSTRUCTIONS

1. **STOP!** Read the safety information above.
2. Set the thermostat to lowest setting.
3. Turn off all electric power to the appliance.
4. This appliance is equipped with an ignition device which automatically lights the pilot. **DO NOT** try to light the pilot by hand.
5. Remove jacket front panel
6. Turn gas control knob clockwise  to "OFF". **DO NOT** force.
7. Wait five (5) minutes (longer for propane) to clear out any gas, then smell for gas, including near the floor. If you then smell gas, STOP! Follow "B" in the safety information above on this page. If you don't smell gas, go to next step.

8. Turn as control knob counterclockwise  to "ON".
9. Replace jacket front panel.
10. Turn on all electric power to the appliance.
11. Set thermostat to desired setting.
12. If the appliance will not operate, follow the instructions "To Turn Off Gas to Appliance" and call your service technician or gas supplier.

To Turn Off Gas to Appliance

1. Set thermostat to lowest setting.
2. Turn off all electric power to the appliance if service is to be performed.
3. Remove jacket front panel.
4. Turn gas control knob clockwise  till knob stops, then continue to "OFF". Do not force.
5. Replace jacket front panel.

Gas Valve VR8204 or VR8304

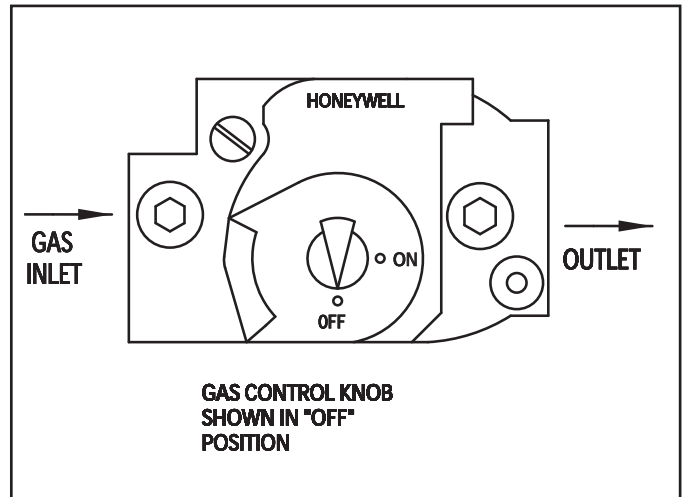

Figure 7.

Removing Jacket Front Panel

1. Turn black screws ¼ turn to open position.
2. Remove front panel.
To replace the panel, reverse procedure.

INTEGRATED BOILER CONTROL

The integrated boiler control monitors the status of the room thermostat, high limit control (AquaStat), pressure switch (air flow proving switch) and the flame sensor. It controls the operation of the circulator, inducer motor (blower), gas valve and spark for pilot ignition. The boiler control also determines the sequence of operation and timing for pre and post purge periods, trial for ignition and lockout. The control indicator lights (LED's) provide information of boiler operation when lights are steady on or diagnostic information when they are flashing in order to help to determine the cause of boiler failure.

INTEGRATED BOILER CONTROL

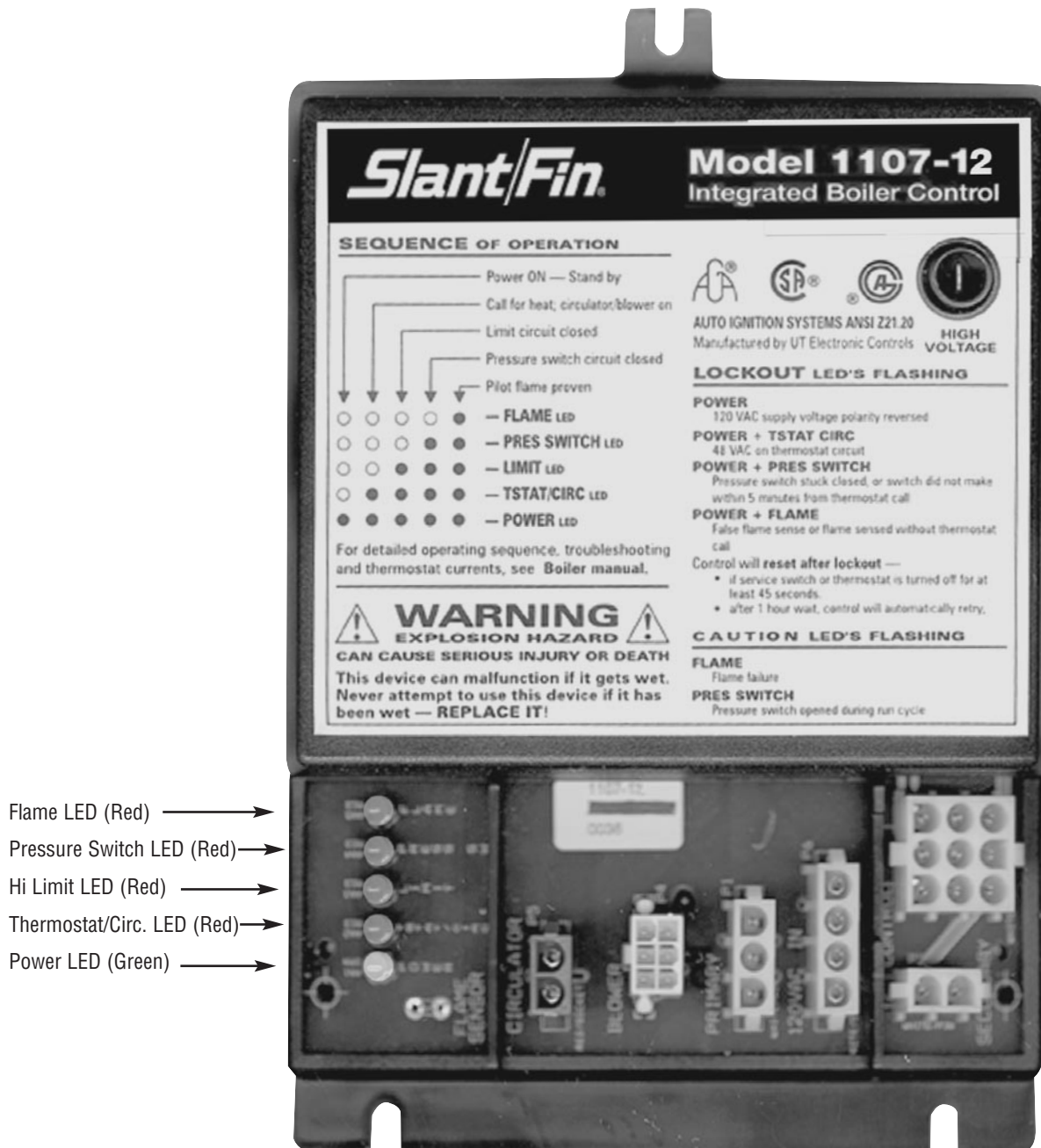

Figure 8.

A. NORMAL OPERATION - STATUS OF INDICATOR LIGHTS (LED'S)

O = LED off ☀ = LED steady on

DESCRIPTION OF OPERATION	POWER LED	TSTAT/CIRC LED	LIMIT LED	PRESS SWITCH LED	FLAME LED
Standby-Boiler waits for call for heat	☀	O	O	O	O
Thermostat calls for heat Circulator on	☀	☀	O	O	O
Boiler water temperature below high limit setting Inducer on	☀	☀	☀	O	O
Pressure switch contacts closed 30 seconds pre-purge period Trial for ignition	☀	☀	☀	☀	O
Gas valve open Pilot flame and main burners on Boiler heating period	☀	☀	☀	☀	☀
Thermostat call for heat ends Circulator off 15 seconds post purge period. Burners off.	☀	O	☀	☀	O

B. DIAGNOSTIC FLASH CODES

Flashing LED's provide diagnostic information

WARNING: Only a trained, experienced service technician should perform troubleshooting. Turn off all electric power to the boiler before service

LED's FLASHING	INDICATION	REMEDY
POWER LED *	120 V power supply. Polarity is reversed	Reverse Hot and NEUTRAL wires in the junction box.
POWER + TSTAT/CIRC LED'S *	48 VAC on thermostat circuit.	Check and correct the thermostat or zone valves wirings.
POWER + PRES SWITCH LED'S *	Pressure switch contacts are closed prior to energizing the blower motor or does not close within 5 minutes of the blower being turned on.	Check air pressure switch. Check hose connections to pressure switch. Check for obstruction/restriction in venting, air intake piping and termination.
POWER + FLAME LED'S *	Flame sensed without call for heat.	Remove air box front panel. Turn off power for at least 45 seconds. Check if pilot flame exists during pre-purge period (first 30 seconds). If pilot flame exists, replace gas valve
FLAME LED *	Pilot flame was not established during trial for ignition.	Check gas valve knob to be in "ON" position. Check inlet gas pressure. Check pilot gas line. Check ignition cable and the connections. Check pilot flame to be "to 1/2" long"
PRES SWITCH LED	Pressure switch opened during boiler run period. Wind gusts over 40 mph.	Check pressure switch and its hoses. Check for obstruction in venting, air intake piping and termination.

* Control Lockout



©Slant/Fin Corp. 2020

**SLANT/FIN CORPORATION, Greenvale, N.Y. 11548 • Phone: (516) 484-2600
FAX: (516) 484-0933 • Canada: Slant/Fin LTD/LTEE, Mississauga, Ontario**

www.slantfin.com