

Slant/Fin

Lifetime Limited Warranty

Galaxy water boilers are so reliable they come with a lifetime limited warranty. Steam models have a 10-year limited warranty.

GALAXY & GALAXY II™

**High performance
gas boilers**



GG SERIES

Hot water models External draft hood



GXHII SERIES

Hot water with tankless coil with external draft hood



GXH SERIES

Steam with or without tankless coil with external draft hood



GXHA SERIES

Steam with or without tankless coil and integral draft diverter

Versatility to meet your home's unique heating needs!

Slant/Fin's Galaxy is one of America's most trusted gas boilers. Installed in tens of thousands of homes, Galaxy is the choice of experienced heating professionals everywhere. For homeowners, it's the wise choice for long-term efficiency and reliability.

Fuel saving performance with traditional cast-iron boiler design

We've fine tuned natural draft cast-iron boiler technology to its most advanced state. With AFUE ratings to 84.0%, Galaxy keeps fuel costs low. It doesn't rely on complex technologies or exotic materials for its efficiency, so there's less to pay for now and less to go wrong. While other boilers become subject to performance and breakdown problems over the years, you can count on Galaxy for efficient, trouble-free performance.

- Thermal targeting technology to conserve fuel by monitoring heating demand *
- Low water cut-off function
- Thermal pre-purge option to save fuel *
- Display shows boiler water temperature and boiler control's setting *
- LED lights provide information of boiler operation *
- Sizes from 95,000 to 399,000 Btuh *
- Hot water and steam models
- Intermittent pilot ignition
- Natural gas or propane
- Tankless heater optional (GXH, GXHII & GXHA models only)
- Low profile steam models available (GXHA)

* Hot water models only

www.slantfin.com



Since 1949
Slant/Fin
BOILERS & BASEBOARD

We Build Trust and Comfort

Slant/Fin

GALAXY™

Built for superb performance and long life.

Each Galaxy boiler is tested in our factory, not in your basement.

We test individual Galaxy boiler sections under pressure of up to 250 p.s.i. (at least 20 times the normal residential operating pressure). Repetitive testing of individual sections, assembled heat exchanger and completed boiler ensures the leak-free integrity of every boiler shipped. Plus, complete testing of the electrical system, valves, wiring and accessories all add to Galaxy's high reliability.

Fast, simple installation. Easy maintenance.

Your Slant/Fin heating contractor can install a new Galaxy boiler in about a day. Packaged hot water models come fully pre-wired and pre-set. For easy access, the front panel goes on and off in seconds. Burners, controls, pilot, combination gas valve and circulator are all mounted and easily within reach from the front of the boiler. On PZ steam models, the convenient speed skimmer trough makes skimming easy for the installer or homeowner.

Galaxy can provide hot water for your kitchen, bath and laundry.

Optional tankless heater. This coil type "instant" hot water maker is located inside the boiler where the constant flow of hot boiler water heats your fresh water as it passes through the coil. Recovery is fast and the total capacity will vary with the boiler size. Available on GXHII Series hot water or GXH steam boilers.



Stainless steel bolts on the cover plate won't rust or break off when servicing the tankless heater.

GALAXY STEAM MODELS

Galaxy steam models are the industry's best solution to system noise and boiler maintenance problems. Galaxy is an ideal replacement boiler for an old steam heating system or for new steam heat jobs. High efficiency models, with intermittent pilot and vent damper, are also among the most efficient steam boilers you can buy. There are 8 Galaxy steam models, all intermittent pilot ignition, all with tankless heater optional. An external draft hood is shipped with each GXH model.

Larger tapings, dry steam.

The Galaxy produces dry steam and delivers it to the system through a 2½" supply tapping. This ensures lower steam velocity and reduces the incidence of water in the mains, resulting in quieter system operation.

Speed skimmer trough.

In any steam boiler installation, it's important that the water is kept free from dirt and contaminants that can cause surging and noise. With ordinary steam boilers, elimination of these contaminants is a cumbersome and time-consuming problem. With the speed skimmer trough built into Galaxy "PZ" steam boilers, skimming time and efforts are reduced dramatically. Surface films of grease, oil and other contaminants cascade into the trough and are discharged through an ordinary ¾" drain cock. It makes skimming as easy as turning a faucet.

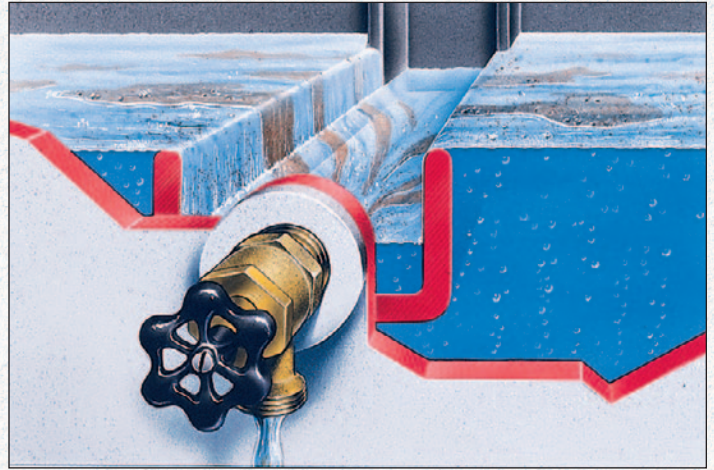

Built-in speed skimmer trough dramatically reduces steam boiler cleaning time.

Low profile GXHA models.

Galaxy GXHA steam models do not require an external draft hood. A built-in integral draft diverter on the four GXHA models reduce clearance requirements above the boiler to 18", making them ideal for use in locations with low chimney breaching or with overhead obstructions.

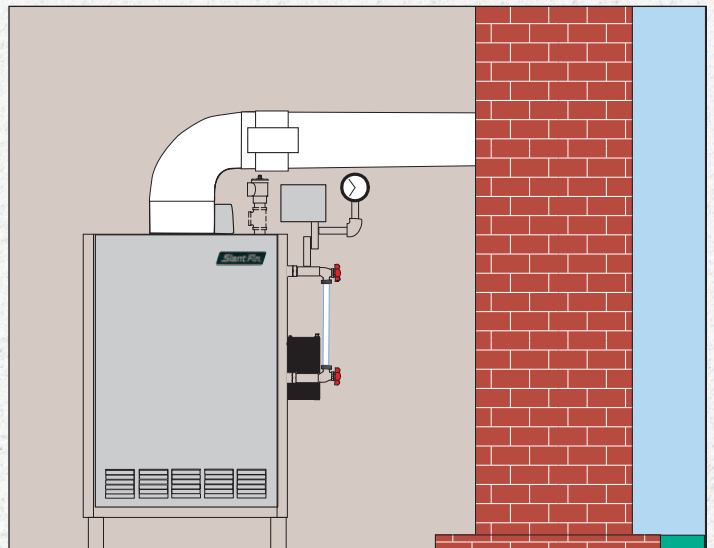

Clearance requirements of just 18" above the boiler make the GXHA steam model ideal for tight installations.

Dimensions

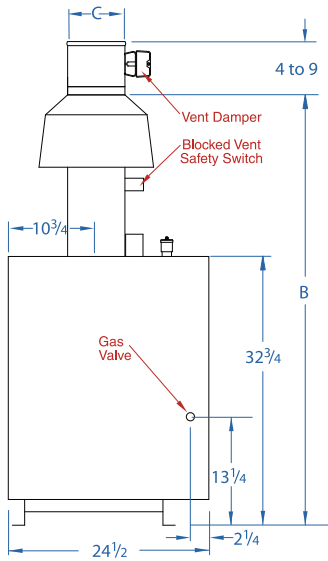

LEFT SIDE VIEW
All GG and GXHII

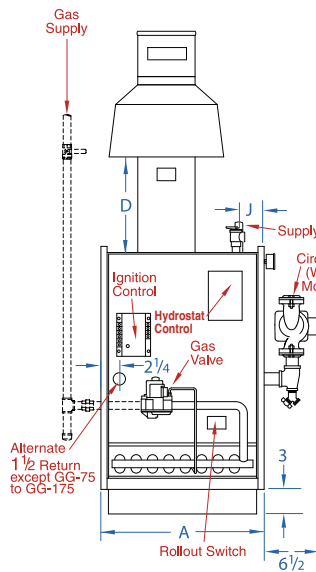

FRONT VIEW
GG and GXHII
Water Models

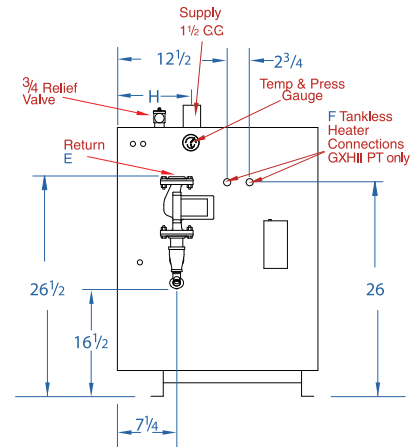

RIGHT SIDE VIEW
GG and GXHII PT
Water Models

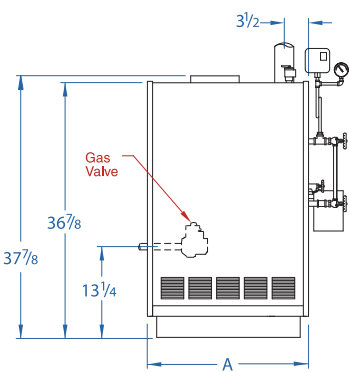

FRONT VIEW
GXHA
Steam Boiler

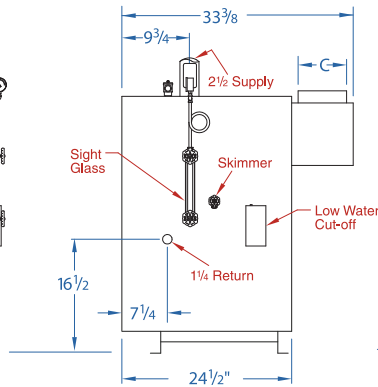

RIGHT SIDE VIEW
GXHA
Steam Boiler

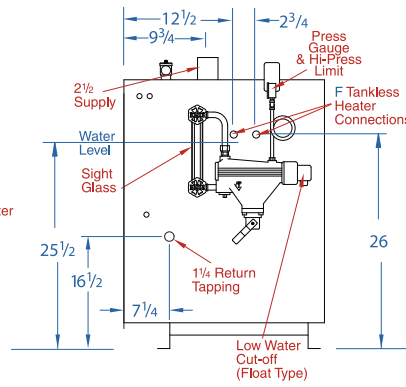

RIGHT SIDE VIEW
GXH
Steam Models

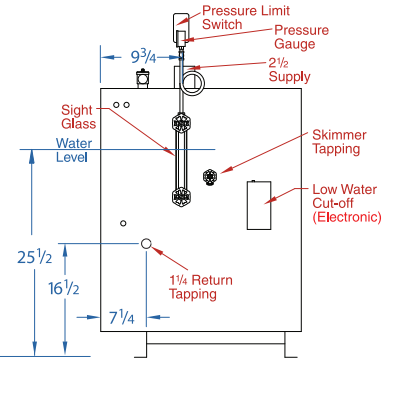

RIGHT SIDE VIEW
GXH
Steam Models

DIMENSIONS INCHES	MODEL GG SERIES — HOT WATER						
	GG-250HEDP	GG-275HEDP	GG-300EDP	GG-350HEDP	GG-350MEDP	GG-375HEDP	GG-399HEDP
A JACKET WIDTH	23 ⁵ / ₁₆	23 ⁵ / ₁₆	26 ¹ / ₁₆	30 ¹ / ₁₆	30 ¹ / ₁₆	30 ¹ / ₁₆	30 ¹ / ₁₆
B DRAFT HOOD HEIGHT	59 ⁵ / ₈	59 ⁵ / ₈	59 ⁵ / ₈	66 ¹ / ₈	66 ¹ / ₈	59 ⁵ / ₈	66 ⁵ / ₈
C FLUE COLLAR DIAMETER	8	8	8	9	9	10	10
D JACKET TOP TO DRAFT HOOD	17	17	17	22 ¹ / ₂	22 ¹ / ₂	15	22
E CIRCULATOR RETURN FLANGE	1 ¹ / ₂	1 ¹ / ₂	1 ¹ / ₂	1 ¹ / ₂	1 ¹ / ₂	1 ¹ / ₂	1 ¹ / ₂
G RIGHT SIDE TO SUPPLY ζ	2 ³ / ₄	2 ³ / ₄	2 ³ / ₄	2 ³ / ₄	2 ³ / ₄	2 ³ / ₄	2 ³ / ₄
H FRONT TO SUPPLY ζ	9 ¹ / ₄	9 ¹ / ₄	9 ¹ / ₄	9 ¹ / ₄	9 ¹ / ₄	9 ¹ / ₄	9 ¹ / ₄

GAS VALVE CONNECTION—Size is ¹/₂" f.p.t. for all models, except GG-250 and larger, which are ³/₄" f.p.t.



DIMENSIONS INCHES	MODEL GXH II & GXH SERIES								MODEL GXHA SERIES			
	HOT WATER WITH TANKLESS HEATER — LOW PRESSURE STEAM WITH OPTIONAL TANKLESS HEATER								LOW PRESSURE STEAM WITH OPTIONAL TANKLESS HEATER			
	GXHII WATER				GXH STEAM							
	GXHII-95EDPT	GXHII-115EDPT	GXHII-135EDPT	GXHII-155EDPT	GXH-230EDPZ	GXH-250EDPZ	GXH-275EDPZ	GXH-300HEDPZ	GXHA-100EDPZ	GXHA-120EDPZ	GXHA-160EDPZ	GXHA-200EDPZ
A JACKET WIDTH	16 ¹ / ₂	16 ¹ / ₂	20	20	23 ⁵ / ₁₆	26 ¹ / ₁₆	26 ¹ / ₁₆	26 ¹ / ₁₆	16 ¹ / ₂	16 ¹ / ₂	20	23 ¹ / ₄
B DRAFT HOOD HEIGHT	50 ⁵ / ₈	51 ¹ / ₄	54 ¹ / ₂	52 ¹ / ₂	55 ¹ / ₂	55 ¹ / ₂	55 ¹ / ₂	59 ¹ / ₈	—	—	—	—
C FLUE COLLAR DIAMETER	5	6	6	6	7	7	7	9	5	6	6	7
D JACKET TOP TO DRAFT HOOD	11	11	13	11	14	14	14	15	—	—	—	—
E CIRCULATOR RETURN FLANGE	1 ¹ / ₄	1 ¹ / ₄	1 ¹ / ₄	1 ¹ / ₄	1 ¹ / ₂	1 ¹ / ₂	1 ¹ / ₂	1 ¹ / ₂	—	—	—	—
F TANKLESS COIL CONNECTIONS	1/2	1/2	1/2	1/2	3/4	3/4	3/4	3/4	1/2	1/2	1/2	3/4
G RIGHT SIDE TO SUPPLY ζ	3 ¹ / ₂	3 ¹ / ₂	3 ¹ / ₂	3 ¹ / ₂	3 ¹ / ₂	3 ¹ / ₂	3 ¹ / ₂	3 ¹ / ₂	3 ¹ / ₂	3 ¹ / ₂	3 ¹ / ₂	3 ¹ / ₂
H FRONT TO SUPPLY ζ	9 ³ / ₄	9 ³ / ₄	9 ³ / ₄	9 ³ / ₄	9 ³ / ₄	9 ³ / ₄	9 ³ / ₄	9 ³ / ₄	9 ³ / ₄	9 ³ / ₄	9 ³ / ₄	9 ³ / ₄

GAS VALVE CONNECTION—Size is ¹/₂" f.p.t. for all models, except GXH-230 and larger, which are ³/₄" f.p.t.

VENT TAPPING: ¹/₂" for all water models.

§ Crates for all models are 30" wide, 38" high, depth 30" (GG-75 through GG-225) and (GXHII-95 through GXHII-155), 38" (GG-250 through GG-399), 40-1/4" (GXH-230 through GXH-300).



Built for superb performance and long life.

GALAXY & GALAXY II™

RATINGS - NATURAL AND L.P. PROPANE GAS

GG SERIES <i>Hot Water Model Ratings</i>				
MODEL NUMBER	RATINGS		NET AHRI RATING WATER (Btuh)*	AFUE %
	CSA INPUT (Btuh)	D.O.E. CAPACITY (Btuh)		
	GG-250HEDP	250,000		
GG-275HEDP	275,000	228,000	198,000	84.0
GG-300EDP	300,000	243,000**	211,000	81.1**
GG-350HEDP	350,000	285,000**	253,000	81.4**
GG-375HEDP	375,000	303,000**	263,000	80.9**
GG-399HEDP	399,000	322,000**	284,000	80.6**

GXHII SERIES <i>Hot Water Model (Tankless Heaters)</i>					TANKLESS HEATER CAPACITY (GPM)‡	VENT SIZE NOMINAL DIA. INCHES
MODEL NUMBER†	RATINGS FOR NAT. & LP PROPANE GAS			AFUE %		
	HOT WATER		NET RATINGS*			
	CSA INPUT (Btuh)	D.O.E. CAPACITY (Btuh)			AHRI WATER (MBH)	
GXHII-95EDPT	95,000	79,000	69.0	84.0	2½	5
GXHII-115EDPT	115,000	96,000	83.0	84.0	3	6
GXHII-135EDPT	135,000	113,000	98.0	84.0	3½	6
GXHII-155EDPT	155,000	130,000	113.0	84.0	3½	6

(Tankless heater) GXHA models have integral draft diverter.

GXH† and GXHA <i>Low Pressure Steam Models</i> (With or Without Coil)							
MODEL NUMBER	RATINGS FOR NAT. & LP PROPANE GAS				AFUE %	TANKLESS HEATER CAPACITY (GPM)‡	VENT SIZE NOMINAL DIA. INCHES
	STEAM		NET RATINGS*				
	CSA INPUT (Btuh)	D.O.E. CAPACITY (Btuh)	AHRI STEAM (MBH)	AHRI STEAM (SQ. FT.)			
GXHA-100EDPZ	100	81,000	61.0	254	82.0	2½	5
GXHA-120EDPZ	120	98,000	73.5	306	82.0	3	6
GXHA-160EDPZ	160	131,000	98.0	408	82.0	3½	6
GXHA-200EDPZ	200	165,000	124.0	516	82.0	4	7
GXH-230EDPZ	231	190,000	142.3	592	82.0	4½	7
GXH-250EDPZ	252	208,000	156.0	650	82.0	4½	7
GXH-275EDPZ	273	226,000	169.5	706	82.0	5	7
GXH-300HEDPZ§	300	239,000**	182.0	758	79.7**	5½	9

Type of gas: After model number, specify gas by name "Natural" or "Propane"
 * Net ratings are based on a piping and pick-up allowance of 1.33 (steam) and 1.15 (hot water). Slant/Fin should be consulted before selecting a boiler for installation having unusual piping and pick-up requirements.
 Ratings must be reduced by 4% at 2,000 feet elevation and an additional 4% for every additional 1,000 feet elevation over 2,000 feet.

† GXH model: "PZ" for steam boiler, "PZT" for packaged steam boiler with tankless heater. Type of gas: After model number, specify gas by name "Natural" or "Propane".
 ** Gross output rating (Btuh) and thermal efficiency
 § Ratings for GXH-300H are for natural gas only.
 ‡ Tankless heater ratings based on intermittent draw.

NOTE: All boilers under 300,000 Btu input are tested and rated for capacity under the U.S. Dept. of Energy (D.O.E.) Test Procedure for boilers.

Equipment

ALL MODELS include pre-assembled heat exchanger; base; flue collector; gas burners; gas orifices and manifold assembly; combination gas valve including manual shut-off, pressure regulator, pilot adj., safety; pressure relief valve (ASME); draft hood (integral draft diverter in GXHA models); blocked vent safety switch; roll-out safety switch; pre-assembled insulated semi-extended jacket (extended as shown); automatic vent damper.

PACKAGED WATER BOILER includes all equipment listed for ALL MODELS and for model S, combination control (hi limit and low limit), circulator; drain cock.

PACKAGED WATER BOILER WITH TANKLESS HEATER (SUFFIX PT) includes all equipment listed for ALL MODELS, plus built-in air eliminator; pressure and temperature gauge; circulator; drain cock; and lo-limit; tankless heater.

PACKAGED STEAM BOILER (SUFFIX PZ) includes all equipment listed for ALL MODELS, plus steam pressure limit control with siphon; pressure gauge; low water cutoff and water level sight glass (unmounted); drain cock, transformer and junction box.

PACKAGED STEAM BOILER WITH TANKLESS HEATER (SUFFIX PZT) includes all equipment listed for ALL MODELS and for model PZ, plus tankless heater; low limit control.

OPTIONAL EQUIPMENT Room thermostat. Air package consisting of diaphragm expansion tank, fill and pressure reducing valve, and automatic air vent. Combustible floor kit.

Before purchasing this appliance read important energy costs and efficiency information available from your contractor.



U.S.A.
 Slant/Fin Corporation • 100 Forest Drive
 Greenvale, NY 11548 • 516-484-2600
 www.slantfin.com

Canada
 Slant/Fin LTD/LTEE • 400 Ambassador Drive,
 Mississauga, Ontario L5T 2J3 • 905-677-8400
 www.slantfin.ca

