

Slant/Fin

SENTINEL

VESTIBULE

High performance, cast-iron gas boiler with Lifetime Limited Warranty

- CSA input: 70,000 to 210,000 Btu/hr
- Intermittent ignition
- Saves energy. A.F.U.E. 84.0%

The smarter choice for informed homeowners.

Enjoy home heating comfort with the extra confidence that an advanced design Sentinel boiler provides. The Sentinel boiler combines the reliability of natural draft and cast-iron construction with the high efficiency performance provided by the Slant/Fin S-Series heat exchanger. A new Sentinel boiler can save 30% or more on fuel bills compared to a typical old boiler operating at 60% efficiency.

- Reliable natural draft design
- Quality control features
- High performance heating
- Thermal targeting technology to conserve fuel by monitoring heating demand
- Low water cut-off function
- Thermal pre-purge option to save fuel
- Display shows boiler water temperature and boiler control's setting
- LED lights provides information of boiler operation



www.slantfin.com



Since 1949
Slant/Fin[®]
Residential & Commercial Boilers

Slant/Fin®

SENTINEL

VESTIBULE



Look for our
Hydronic Explorer app
 on iTunes, Google Play and at
www.hydronicexplorer.com
 (Works on iPad, iPhone & Android devices)

High performance, cast-iron gas boiler

With five models ranging in size from 70,000 to 210,000 Btuh, Sentinel boilers meet a wide range of residential and light commercial heating requirements. All models are available for use with natural gas or L.P. gas.

Sentinel boilers are “installer-friendly”, with features to make the contractor’s installation and set up quicker and easier. All Slant/Fin boilers, for instance, are packaged in quick release shipping crates to speed up unpacking. Boilers are factory-wired with quick connect harnesses for the vent damper and blocked vent safety switch. Controls are all mounted on the outside of the boiler for easy access and quick wiring. The boiler height, including draft diverter, is up to a foot and a half lower than many natural draft boilers. (For lower profile boilers with integral draft hoods, refer to the Slant/Fin Sentry models).

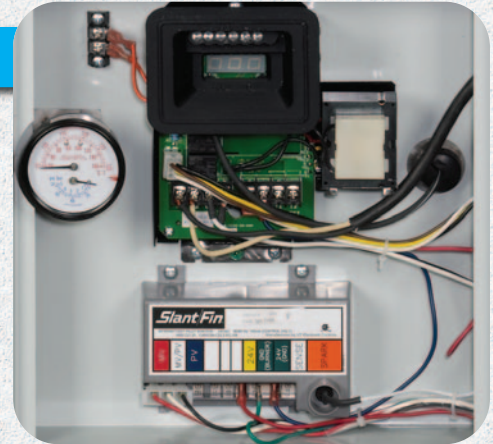

- Computer-aided design
- Highest quality manufacturing
- Superior components

RATINGS FOR SENTINEL BOILERS – NATURAL AND L.P. GAS

SENTINEL SERIES RATINGS						DIMENSIONS			
MODEL NUMBER †	CSA INPUT (Btuh)	DOE CAPACITY (Btuh)	NET AHRI RATING WATER (Btuh) *	WATER (Sq.Ft.)	AFUE %	A	B	C	D
					INTERMITTENT IGNITION				
SE-70	70,000	58,000	50,000	333	84.0	11½"	17½"	4"	45½"
SE-105	105,000	87,000	76,000	507	84.0	14½"	20½"	5"	46¾"
SE-140	140,000	116,000	101,000	673	84.0	17½"	23½"	5"	46¾"
SE-175	175,000	145,000	126,000	840	84.0	20½"	26½"	6"	47"
SE-210	210,000	173,000	150,000	1000	84.0	23½"	29½"	6"	48¾"

* Net ratings are based on a piping and pick-up allowance of 1.15. Slant/Fin should be consulted before selecting a boiler for installation having unusual piping and pick-up requirements. Ratings must be reduced by 4% at 2,000 feet elevation and an additional 4% for every additional 1,000 feet elevation over 2,000 feet.

†Type of gas: after model number, specify gas by name "Natural" or "Propane".
 Note: All Sentinel boilers are tested and rated for capacity under the U.S. Dept. of Energy (D.O.E.) Test Procedure for boilers.

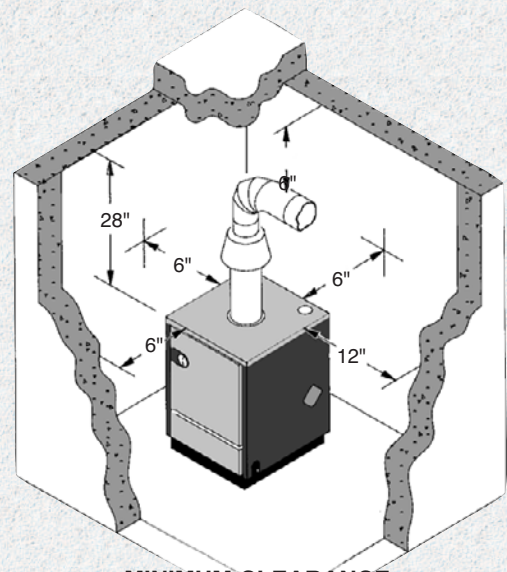
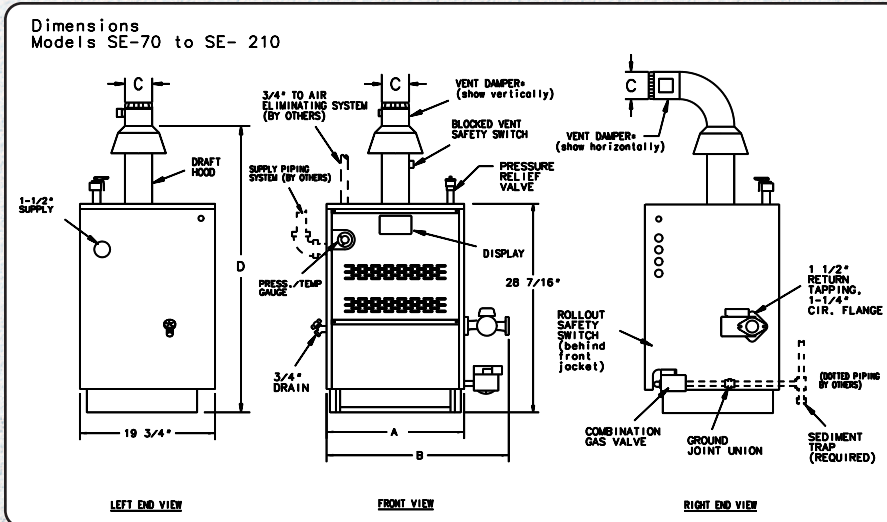

MINIMUM CLEARANCE DIMENSIONS



U.S.A.
 Slant/Fin Corporation • 100 Forest Drive
 Greenvale, NY 11548 • 516-484-2600
www.slantfin.com

Canada
 Slant/Fin LTD/LTEE • 400 Ambassador Drive,
 Mississauga, Ontario L5T 2 J3 • 905-677-8400
www.slantfin.ca